

XRF4

64x128 Ultra High Density 4RU L-Band/Wideband RF Router

The XRF4 is an ultra-compact wideband RF router for signals from 850–2450MHz. Featuring a 64x128 matrix configuration with direct fiber input modules and touch panel with integrated spectrum analyzer, the XRF4 is a fully-integrated RF routing solution. Starting from a base 8x8 configuration, the XRF4 is a modular, scalable platform that offers flexible expansion options.

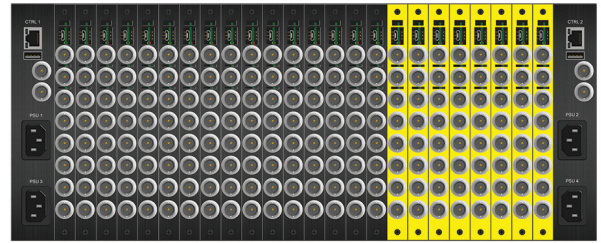

► Features & Benefits

Performance

Industry's best performing large-capacity router with superior frequency response, isolation, return loss and noise figure to preserve signal margin.

Flexibility

Various connector options, adjustable gain and direct fiber options offer flexibility to meet any application requirement. Built-in gain allows expansion up to 512x1024 using Evertz' passive splitters & combiners with no added point of failure.

Reliability

All active components are modular and hot-swappable, facilitating quick serviceability and maximum uptime.

LNB Powering

Optional integrated LNB power supplies, individually controllable on all inputs. Active current protection, advanced monitoring/alarming and automatic recovery per port.

Monitoring & Control

Integrated 10" touch screen display and built-in spectrum analyzer allow quick control and monitoring of all routes using customizable graphical user interfaces. User-friendly web browser provides access to all router controls and monitoring using Evertz' own VistaLINK PRO third-party compatible SNMP software. Immediate control and monitoring of routes, gain, threshold adjustments, RF power levels and LNB current values using Evertz' own MAGNUM control software.

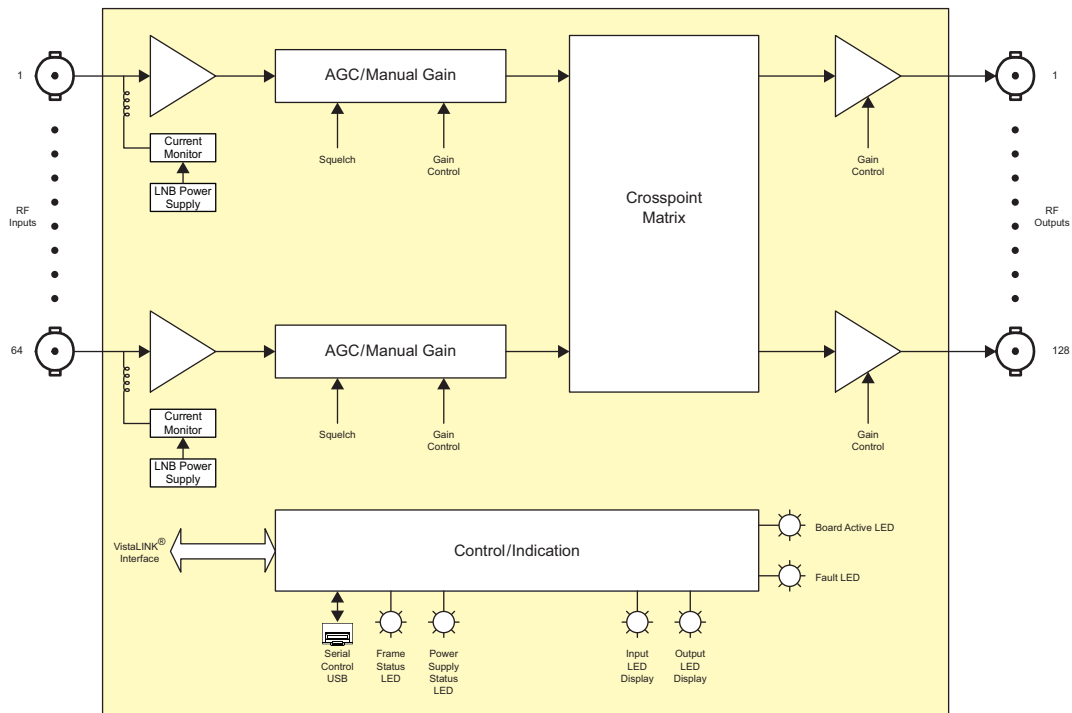

The Complete Solution Provider



► Specifications

<p>System: Matrix Sizes: 8x8 to 64x128 in a 4RU frame System Expansion: Inputs/outputs expandable in increments of 8, expansion beyond 64x128 requires additional frames and external splitting/combining up to 512x1024 Impedance: 75Ω (50Ω optional) Connector Type: BNC (SMA and F-type also available) Input Gain Range: -15dB to +15dB in 0.5dB steps Output Gain Range: -30dB to +30dB in 0.5dB steps</p>	<p>Isolation: >65dB output to output >65dB input to input >60dB input to output RF Input Power: -5dBm to -55dBm Max RF Output Power: -5dBm Input P1dB: 0dB OIP3: > +12dBm Return Loss: > 17dBm typ. >14dBm min (Input and Output) Group Delay: <2.0ns Gain Tracking: ±2.0dB</p>	<p>Communication & Control: Ethernet: SNMP, Quartz Protocol, Web Browser Panels: Integrated 10" touch screen panel, CP2116-E, CP2232-E panels available Software: Web, VistaLINK PRO SNMP NMS, and VUE-SW</p>
<p>RF Specifications: Bandwidth: 850MHz to 2450MHz Frequency Response: ±1.5dB typ. ±2.0dB max ±0.25dB typ. ±0.5dB max over any 36MHz bandwidth</p>	<p>LNB Power: Voltage: 13/18V DC, off (selectable) Current: 400mA Protection: Active: short circuit, overload 22kHz Tone: On/off</p>	<p>Electrical: AC Input: Auto-ranging, 100-240V AC, 50/60Hz Connector: IEC 60320-1 per power supply Number: 4 (1+3)</p> <p>Physical: Dimensions: 18.96" W x 6.96" H x 29.21" D (482mm W x 177mm H x 742mm D)</p>

► Ordering Information

XRF4-FR XRF 4RU router frame, 192x IO connections, 75Ω BNC connectors, with 10" integrated LCD touch screen

Ordering Options:

- XRF4-8IP** 8-channel input card for XRF RF router system, 75Ω BNC connectors
- XRF4-8OP** 8-channel output card for XRF RF router system, 75Ω BNC connectors

XRF4-MP
XRF4-FC
XRF4-FC-SA

XRF4-PS
-B50
-S50
-F75

XRF4 system mid-point module
 XRF4 RF router frame controller
 Frame controller with integrated spectrum analyzer for the XRF4 router system; accessible locally using 10" touch screen or over the network using web browser
 XRF4 RF router power supply module
 50Ω BNC connectors
 50Ω SMA connectors
 75Ω F connectors



Esatcom Inc.
www.esatcom.com

Tel:
 718.276.0800

Email:
sales@esatcom.com