

## v100NX

### ALL NEW KU-KA DUAL BAND GEO/MEO/LEO 1m Maritime VSAT Terminal



#### FEATURES

##### KU-KA DUAL BAND READY

The v100NX is the Ku- to Ka-band convertible antenna that can be simply converted from Ku- to Ka-band. The reflector and radome are frequency tuned for both satellite bands, ensuring maximum performance in both bands

##### GEO/MEO/LEO TRACKING CAPABILITY

The v100NX is ready for the future. Designed with the world's most accurate satellite tracking performance with our proven tracking algorithm covering GEO, MEO and LEO constellations.

##### 2.5 GHZ WIDEBAND KA READY

The v100NX uses 2.5GHz wideband Ka tuned Radome & Reflector. It provides the convenience of not having to replace the Radome and Reflector when using 2.5GHz service in the future.

##### SINGLE COAXIAL CABLE

The v100NX integrates RF and power cables into one coaxial cable. A single cable carries Tx, Rx, DC power, data and reference signals between the antenna and the BOT.

##### STANDARDIZED MODULAR COMPONENTS ACROSS NX SERIES

Modular components are used throughout the NX range, such as dynamic motor brakes with integrated encoders, Main Control Unit and skew assembly. Sharing common modules across Intellian's NX antenna series, the number of spare parts is reduced.

##### NEW APTUSNX

Intellian's all new integrated M&C platform, AptusNX provides responsive web user interface to manage and control the antenna system regardless of device types. Installation Wizard in AptusNX automates functions for system configuration so that operators are minimally involved in system installation and operation, including automatic cable loss compensation, line-up test and auto diagnostics.

## v100NX

### TECHNICAL SPECIFICATIONS

#### ABOVE DECK UNIT

Radome Height	145.8 cm / 57.4"
Radome Diameter	137.9 cm / 54.3"
Reflector Diameter	105 cm / 41.3"
Weight	113 kg / 249.1 lbs
Azimuth Range	Unlimited
Elevation Range	-20° to 115°
Cross-level Range	± 37°
Stabilization Accuracy	0.2° peak mispointing @ max ship motion condition
Motor Brake System	Dynamic Brake System
Tx Frequency	13.75 ~ 14.5 GHz Ku-band
Tx Gain	42.0 dBi @ 14.25 GHz (excl. radome)
Rx Frequency	10.7 ~ 12.75 GHz Ku-band
Rx Gain	40.7 dBi @ 11.7 GHz (excl. radome)
G/T	> 20.0 dB/K @ 12.75 GHz (Clear Sky, 30° Elevation)
BUC Power	8W, 16W, 25W (Optional)
LNB	Intellian PLL LNB
Polarization	Linear, Cross & Co-pol
Antenna Cable	Single 50ohm Coax Cable for Rx, Tx, FSK, Reference and Power from ACU to ADU

#### ANTENNA CONTROL UNIT

Dimensions (WxDxH)	43.1cm x 35cm x 4.4cm / 17" x 13.8" x 1.7"
Weight	5.2 kg / 11.5 lbs
Display	OLED Display
Gyrocompass Interface	NMEA2000, NMEA0183
Mediator Interface	Yes
Modem Interface	Ethernet port / RS-232C, -422C / I/O Console
Modem Protocol	iDirect, Comtech, SatLink, Hughes, GILAT, Newtec
Wi-Fi Operation	Yes (w/ Wi-Fi dongle)
Management Port	Yes
Intellian LAN Port	Yes
Power Requirement	100 ~240 VAC, 50~60Hz, 4A

### SYSTEM DIMENSION

#### ADU

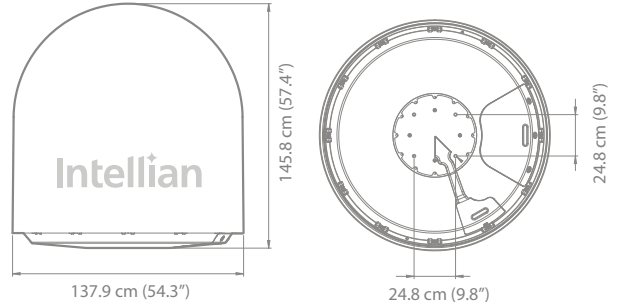

### SYSTEM DIAGRAM



### SYSTEM DIAGRAM (DUAL ANTENNA)

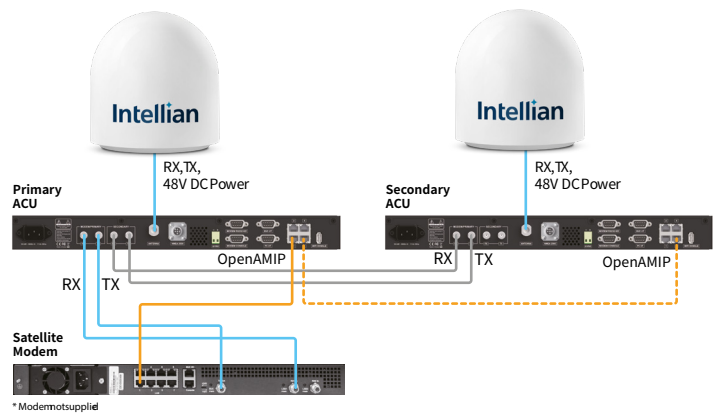

Esatcom Inc.  
www.esatcom.com

Tel:  
718.276.0800

Email:  
sales@esatcom.com