



LNB

C-BAND 5000I

PLL



FEATURES

Ideal for DBV (Digital Broadcast Video), VSAT Broadband, Military Satcom, Point-of-Sale, and Oil and Gas applications

- LO Stability +/- 50 kHz to +/-100 kHz
- 15 K noise temperature
- 580 grams / 20.5 ounces

FREQUENCY BANDS AVAILABLE

Input frequency (GHz)	4.5 - 4.8 GHz
L.O. frequency (GHz)	5.95 GHz
Output frequency (MHz)	1150 – 1450 MHz

MECHANICAL DIAGRAM

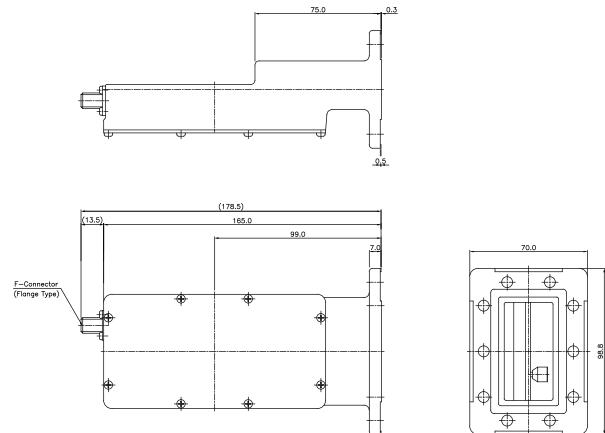

TYPICAL SPECIFICATIONS

L.O. stability	±50 kHz – ±100 kHz depending on model number
Noise temperature	15 K typ., 30 K max.
Phase noise	-65 dBc/Hz @ 1 kHz offset -80 dBc/Hz @ 10 kHz offset -95 dBc/Hz @ 100 kHz offset
Input VSWR & Output VSWR	2.3:1
Conversion gain	62 dB typical 55 dB min 70 dB max
Output P1dB	10 dBm
Power requirements	12 - 24V DC supplied through center conductor of IF cable
Current drain	250 mA
Input Waveguide	CPR 229G
Dimensions	190 (L) x 115 (W) x 78 (H) mm (7.1 x 4.0 x 2.8 in)
Weight	580 g / 20.5 oz
Temperature Range	-40°C to +60°C

HOW TO ORDER

5500IF	CONNECTOR	F - 75 Ohm N - 50 Ohm
	L.O. STABILITY	5 - ±50 kHz 7 - ±75 kHz 1 - ±100 kHz
	LNB SERIES #	

