

Released

- Specification -

C-band 3W BUC

Model No. NJT8103 series

RF Frequency	Local Frequency	IF Frequency
5.85 to 6.425 GHz	4.9 GHz	950 to 1,525 MHz
5.85 to 6.725 GHz	4.9 GHz	950 to 1,825 MHz
6.725 to 7.025 GHz	5.76 GHz	965 to 1,265 MHz

Output Power @ 1dB G.C.P.: +34.5 dBm (3W)

IF Input Interface: N-type / F-type, Female Connector

DC Power / Ref. (10MHz) Input: IF Connector

RF Output Interface: Waveguide, CPR-137G

DC Power Voltage Range: +12 to +30 V

Copyright©

Nisshinbo Micro Devices Inc.
Microwave Business Division

-Notice of Proprietary Information-

This document and its contents are proprietary to Nisshinbo Micro Devices Inc.
This publication and its contents may not be reproduced or distributed for any other purpose
without the written permission of Nisshinbo Micro Devices Inc.

Those specifications listed in this document are subject to change at any time.



Caution

1. While Nisshinbo Micro Devices Inc. (NISD) continually strives to improve the quality and reliability of our products, failures will occur in microwave products over time. For this reason, it is important that customers fulfill their responsibilities to ensure designed-in safety – including failsafe functions, redundancy, and measures to prevent malfunctions and the spread of fire – in order to avoid injuries, accidents, or social repercussions resulting from the failure of any products related to satellite communications on this document (hereinafter, “the product”). Customers must pay careful attention to ensuring the safety of their equipment.
2. The product is designed and tested to function in accordance with its specifications. Do not use under conditions that deviate from the product specifications included in the delivery specifications. NISD assume no responsibility and shall not be liable for any injuries, accidents, or social repercussions resulting from the product being in a poor or damaged state because it was used under conditions that depart from the specifications.
3. The product is covered by a warranty for one year following delivery unless otherwise stipulated in the contract or delivery conditions. In the event of a failure for which NISD are responsible occurring during the warranty period, NISD undertake to repair or replace the product free of charge. Note, however, that the warranty does not cover failures such as those listed here (see bullets below), even if they occur within the warranty period. In addition, in the case of a product being repaired or replaced by us, the starting date for the warranty period is still the original delivery date of the product.
 - Failure due to the product being used in conditions other than those stipulated in the data sheet, specification sheet, etc.
 - Failure due to modifications or repairs carried out by some entity other than our company
 - Failure determined to be the result of unsuitable maintenance or replacement of a consumable item that requires due maintenance
 - Failure due to circumstances that were unforeseeable given the scientific/technological standards at the time of shipment
 - Other failures due to external factors such as fire, earthquake, flood and power supply anomalies for which NISD are not responsible

In addition, the product warranty is limited to the provision of repair services or replacement at no cost. It does not cover secondary damage (to equipment, business opportunities, profits, etc.) or any other damage that may have resulted from failure of the product.

4. The product must be handled appropriately to ensure its continued reliability. Since it can be damaged by the intrusion of water, dust, oil, chemicals, etc., it must be given appropriate protection. Even in the case of a product with an airtight construction, avoid using it in an environment that exceeds the stated levels of waterproofing/dustproofing. Also, be sure to use connectors and waveguides properly.
If replacement parts such as fans are included, proper maintenance is necessary. To maintain product performance and functionality, it is necessary to conduct inspections and maintenance at appropriate intervals and exchange replacement parts when necessary. Improper inspections or maintenance may result in failure.
In addition, the warranty does not cover the use of the product in areas where salt damage can be expected or where there is a substantial presence of corrosive gases such as Cl₂, H₂S, SO₂, and NO₂. If the product is to be used in such areas, at the time of installation you must take appropriate steps to protect the product.
5. If the product is to be used with equipment/systems that must meet special quality and reliability standards (aerospace equipment, medical equipment, power generation control equipment, automotive/railway transportation equipment, safety equipment, disaster prevention and security equipment, etc.), please consult with our sales staff in advance.
6. Some products contain gallium arsenide (GaAs), classified as a harmful substance. To avoid danger, do not incinerate, crush, or chemically treat the product in such a way that gases or dust are released. When disposing of the product, comply with all applicable laws and regulations and do not treat it as general industrial waste or household waste.
7. When exporting a product or technology, observe export laws and regulations such as those governing foreign exchange and foreign trade, and obtain any necessary licenses for export, service transactions, etc.
NISD request that you do not use our products or the technical data published on this document for developing weapons of mass destruction or for any other military purposes or applications.
8. The product specifications in this document are subject to change without notice. If you are considering using a product, delivery specifications must first be settled.

* Above Specifications are subject to change without notice.

Scope

This BUC is designed for the block up-converter intended for the satellite communication data uplink application in C-band. It can transmit an RF signal (C-band: 5.85 to 6.425 GHz, 5.85 to 6.725 GHz, or 6.725 to 7.025 GHz) output with up to 3W (+34.5 dBm) linear as output power @ 1 dB G.C.P. (P1dB). It is combined a GaAs high power amplifier and a block up-converter with a phase locked local oscillator (4.9 GHz or 5.76 GHz) which is synchronized with external 10MHz reference.

The BUC receives a reference signal (10 MHz) and an IF signal (L-band: 950 to 1,525 MHz, 950 to 1,825 MHz, or 965 to 1,265 MHz) input and transmits an RF signal (C-band: 5.85 to 6.425 GHz, 5.85 to 6.725 GHz, or 6.725 to 7.025 GHz) output. It is operated by +24 V DC power (Range: +12 to +30 V) input.

The BUC comes in a single, weatherized housing rated for outdoor use and has either an N-Type or F-type female connector as IF input, a CPR-137G waveguide flange as RF output.

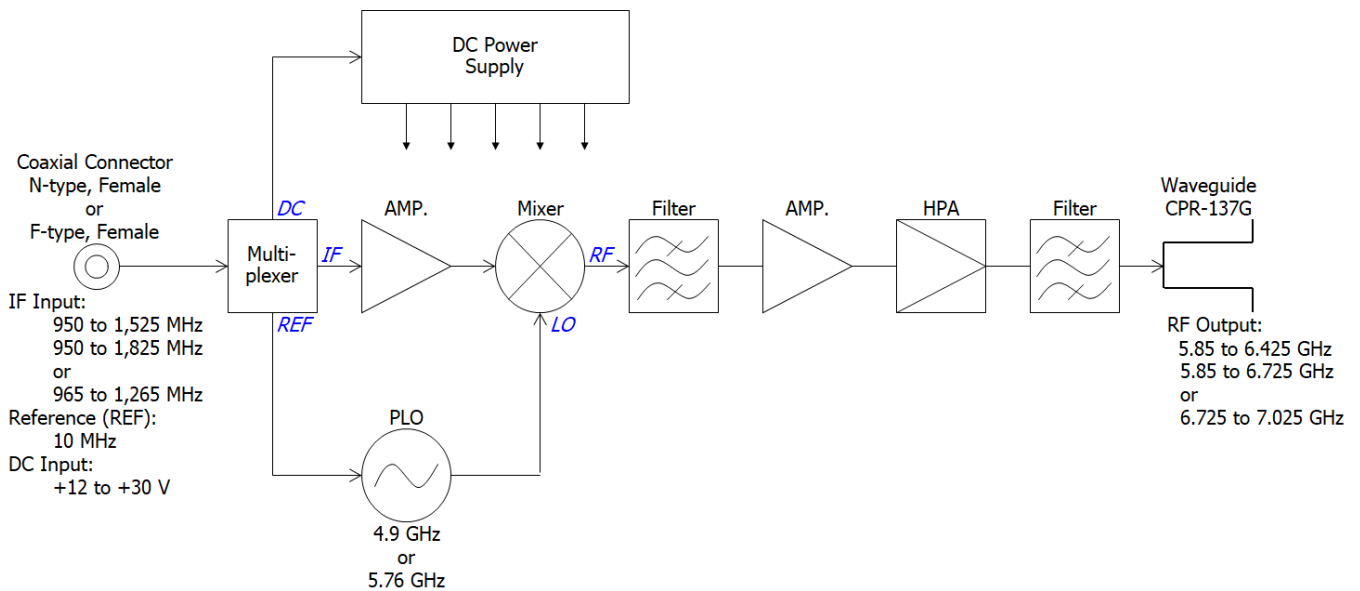
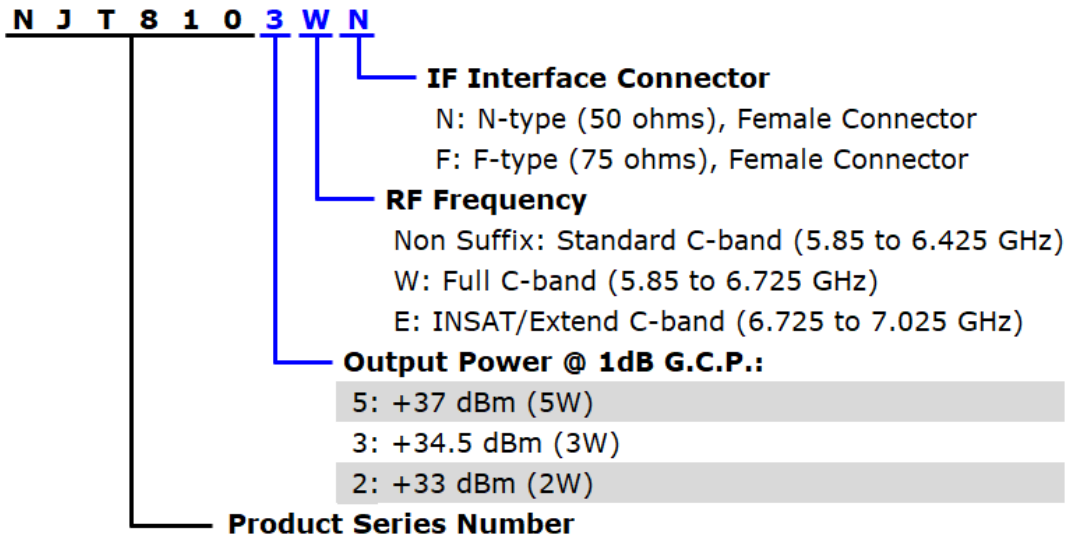

Fig.1 Functional Block Diagram

* Above Specifications are subject to change without notice.

Series Model Number

- Numbering System



- Line-up

Model No.	RF Frequency	Local Frequency	IF Frequency	Output Power @ P1dB	IF Connector
NJT8105N	5.85 to 6.425 GHz (Standard C-band)	4.9 GHz	950 to 1,525 MHz	5W Linear (+37 dBm min.)	N-type
NJT8105F					F-type
NJT8103N				3W Linear (+34.5 dBm min.)	N-type
NJT8103F					F-type
NJT8102N				2W Linear (+33 dBm min.)	N-type
NJT8102F					F-type
NJT8105WN	5.85 to 6.725 GHz (Full C-band)	4.9 GHz	950 to 1,825 MHz	5W Linear (+37 dBm min.)	N-type
NJT8105WF					F-type
NJT8103WN				3W Linear (+34.5 dBm min.)	N-type
NJT8103WF					F-type
NJT8102WN				2W Linear (+33 dBm min.)	N-type
NJT8102WF					F-type
NJT8105EN	6.725 to 7.025 GHz (INSAT/Extend C-band)	5.76 GHz	965 to 1,265 MHz	5W Linear (+37 dBm min.)	N-type
NJT8105EF					F-type
NJT8103EN				3W Linear (+34.5 dBm min.)	N-type
NJT8103EF					F-type
NJT8102EN				2W Linear (+33 dBm min.)	N-type
NJT8102EF					F-type

* Above Specifications are subject to change without notice.

1. Electrical Specifications

#	Items	Specifications
1.1.	Output RF Frequency Range	
	<Standard C-band>	5.85 to 6.425 GHz
	<Full C-band>	5.85 to 6.725 GHz
	<INSAT/Extend C-band>	6.725 to 7.025 GHz
1.2.	Input IF Frequency Range	
	<Standard C-band>	950 to 1,525 MHz
	<Full C-band>	950 to 1,825 MHz
	<INSAT/Extend C-band>	965 to 1,265 MHz
1.3.	Maximum IF Input Level (without damage)	+13 dBm max.
1.4.	Conversion Type	Single, fixed L.O.
1.5.	L.O. Frequency	
	<Standard C-band>	4.9 GHz
	<Full C-band>	4.9 GHz
	<INSAT/Extend C-band>	5.76 GHz
1.6.	Frequency Sense	Positive
1.7.	Output Power @ 1dB G.C.P. (P1dB)	+34.5 dBm min. over temperature
1.8.	Linear Gain	59 dB nom., 53 dB min.
1.9.	Gain Variation over frequency @ fixed temperature	
	<Standard C-band>	5 dBp-p max. over 575 MHz 2 dBp-p max. over 36 MHz
	<Full C-band>	5 dBp-p max. over 875 MHz 2 dBp-p max. over 36 MHz
	<INSAT/Extend C-band>	4 dBp-p max. over 300 MHz 2 dBp-p max. over 36 MHz
1.10.	Gain Stability over temperature @ fixed frequency	5 dBp-p max. 2 dBp-p typ.
1.11.	ACPR / Regrowth Modulation Condition: Output Power: +34.5 dBm Modulation: QPSK Symbol Rate: 1 Msps Data Type: PN23 FIR filter: RNYQ, $\alpha = 0.3$	-26 dBc typ. at 1 MHz offset from modulation center frequency

* Above Specifications are subject to change without notice.

#	Items	Specifications
1.12.	Requirement for External Reference <div style="margin-left: 100px;">[Frequency]</div> <div style="margin-left: 100px;">[Input Power]</div> <div style="margin-left: 100px;">[Phase Noise]</div>	10 MHz (sine-wave) -5 to +5 dBm @ Input port -120 dBc/Hz max. @ 100 Hz -130 dBc/Hz max. @ 1 kHz -140 dBc/Hz max. @ 10 kHz
1.13.	L.O. Phase Noise	-60 dBc/Hz max. @ 100 Hz -70 dBc/Hz max. @ 1 kHz -80 dBc/Hz max. @ 10 kHz -90 dBc/Hz max. @ 100 kHz -100 dBc/Hz max. @ 1MHz
1.14.	Spurious @ Pout = +34.5 dBm	
	<Standard C-band>	
	[In-band]	-50 dBc max. @ 5.85 to 6.425 GHz
	[Receive-band]	-70 dBm max. @ 3.625 to 4.2 GHz
	[Out-of-band]	-50 dBc max.
	<Full C-band> *Note 1	
	[In-band]	-50 dBc max. @ 5.85 to 6.725 GHz
	[Receive-band]	-70 dBm max. @ 3.4 to 4.2 GHz
	[Out-of-band]	-50 dBc max.
	<INSAT/Extend C-band>	
	[In-band]	-50 dBc max. @ 6.725 to 7.025 GHz
	[Receive-band]	-70 dBm max. @ 4.5 to 4.8 GHz
	[Out-of-band]	-50 dBc max.
1.15.	Receive Band Noise Density	
	<Standard C-band>	-87 dBm/4kHz max. @ 3.625 to 4.2 GHz
	<Full C-band>	-87 dBm/4kHz max. @ 3.4 to 4.2 GHz
	<INSAT/Extend C-band>	-87 dBm/4kHz max. @ 4.5 to 4.8 GHz
1.16.	Noise Figure	20 dB max.
1.17.	Input Impedance	
	<N-type Model>	50 ohms nom
	<F-type Model>	75 ohms nom.
1.18.	Input V.S.W.R.	2 : 1 max.
1.19.	Output V.S.W.R.	2 : 1 max.
1.20.	Output Load V.S.W.R.	
	[Recommendation]	1.3 : 1 max.
	[Non Damage]	Infinite : 1

* Above Specifications are subject to change without notice.

#	Items	Specifications
1.21.	DC Power Requirement [Voltage Range] [Power Consumption]	+24 VDC (+12 to +30 VDC) 21 W typ., 25 W max. @ Pout = +34.5 dBm 18 W typ. @ No IF signal 2 W max. @ 10 MHz reference off (Mute on)
1.22.	Mute	Shut off the HPA in case of L.O. unlocked or no 10 MHz reference signal.

*Note1: The 2nd harmonics level of IF signal must be lower than -60 dBc at the IDU and IF signal source output.

* Above Specifications are subject to change without notice.

2. Mechanical Specifications

#	Items	Specifications
2.1.	Input Interface	IF / Ref. / DC Power Input:
	<N-type Model>	Coaxial Connector, N-type Female - 50 ohms
	<F-type Model>	Coaxial Connector, F-type Female - 75 ohms
2.2.	Output Interface	Waveguide, CPR-137G (with Groove)
2.3.	Dimension & Housing without interface connectors and screws	135.4 (L) × 85 (W) × 56 (H) mm [5.33" (L) × 3.35" (W) × 2.20" (H)]
2.4.	Weight	800 g [1.8 lbs]
2.5.	Cooling	Convection Air Cooling

3. Environmental Specifications

#	Items	Specifications
3.1.	Temperature Range (Ambient)	
	[Operating]	-40 to +60 °C
	[Storage]	-40 to +75 °C
3.2.	Humidity	0 to 100 % RH
3.3.	Altitude	15,000 feet (4,572 m)
3.4.	Vibration (Survival)	5 G [49.03 m/s ²] (3 axis, 50 Hz to 2 kHz)
		1 mm p-p (3 axis, 5 to 50 Hz)
3.5.	Shock (Survival)	30 G [294.20 m/s ²] (3 axis)
3.6.	Waterproof / Dustproof (IP Code Rating)	IP 67
3.7.	Regulations	EU Directive (CE Marking) RE - 2014/53/EU EMC - 2014/30/EU RoHS - 2011/65/EU + (EU)2015/863 Safety: EN62368-1, EN60950-22
3.8.	MTBF (by Method of Parts Count Reliability Prediction)	150,000 hours and more at +60 °C as Design Condition

* Above Specifications are subject to change without notice.

4. Outline Drawing

4.1. N-type Model

UNIT: mm
Tolerance: ±0.5

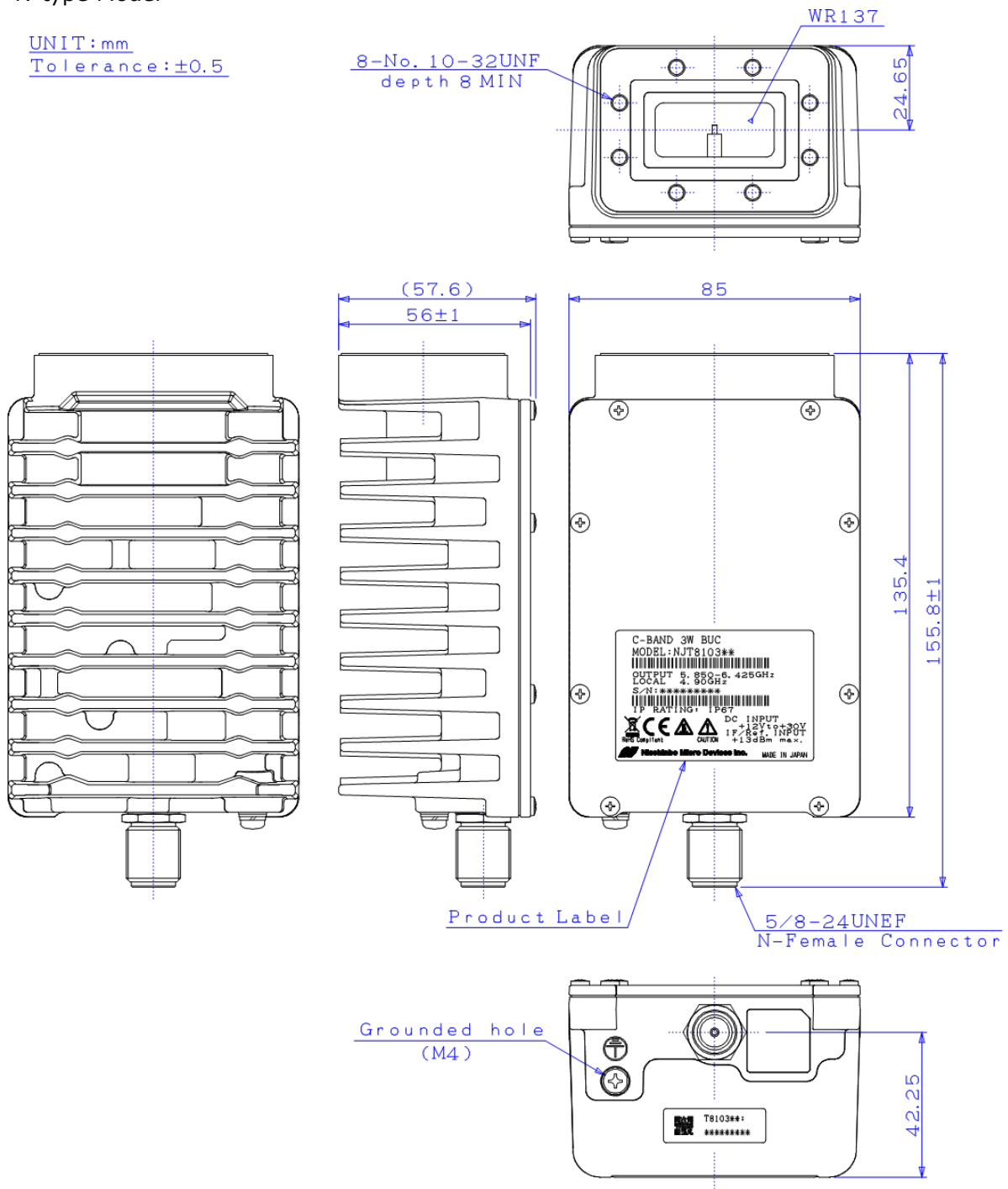

CAUTION

Items	Description
Hot Surface	Whole of body and heat sink is hot when this unit is powered, and even after power is disconnected until it is cooled down. Do not touch hot surface to avoid a burn hazard.
RF Radiation	A radiation hazard exists if this unit is operated with its RF signal output unterminated. Do not operate this unit without a load or termination attached to the RF signal output.

* Above Specifications are subject to change without notice.

4.2. F-type Model

UNIT: mm
Tolerance: ±0.5

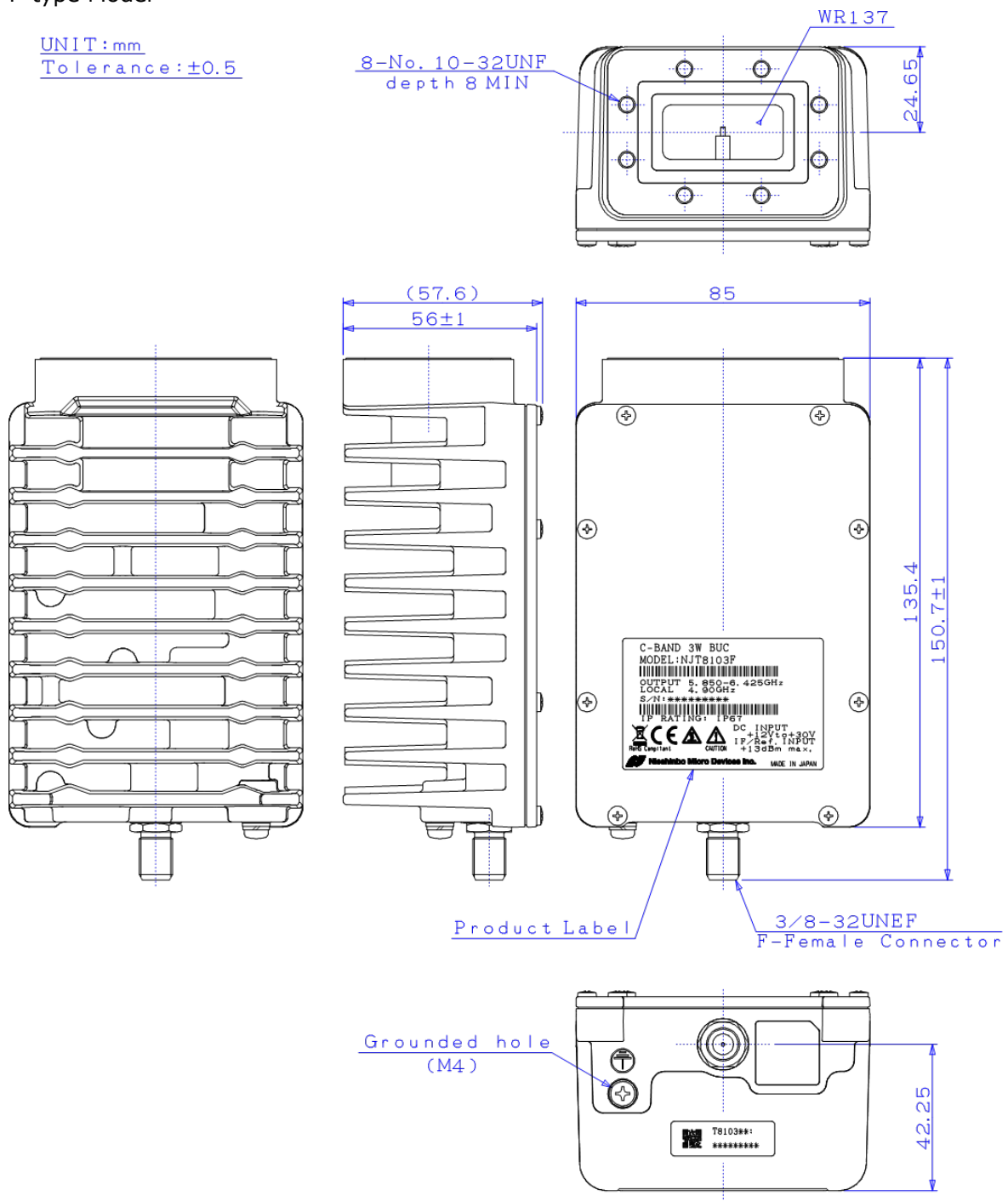

CAUTION

Items	Description
Hot Surface	Whole of body and heat sink is hot when this unit is powered, and even after power is disconnected until it is cooled down. Do not touch hot surface to avoid a burn hazard.
RF Radiation	A radiation hazard exists if this unit is operated with its RF signal output unterminated. Do not operate this unit without a load or termination attached to the RF signal output.

* Above Specifications are subject to change without notice.

5. Label

5.1. Label Outline (e.g. NJT8103WF)

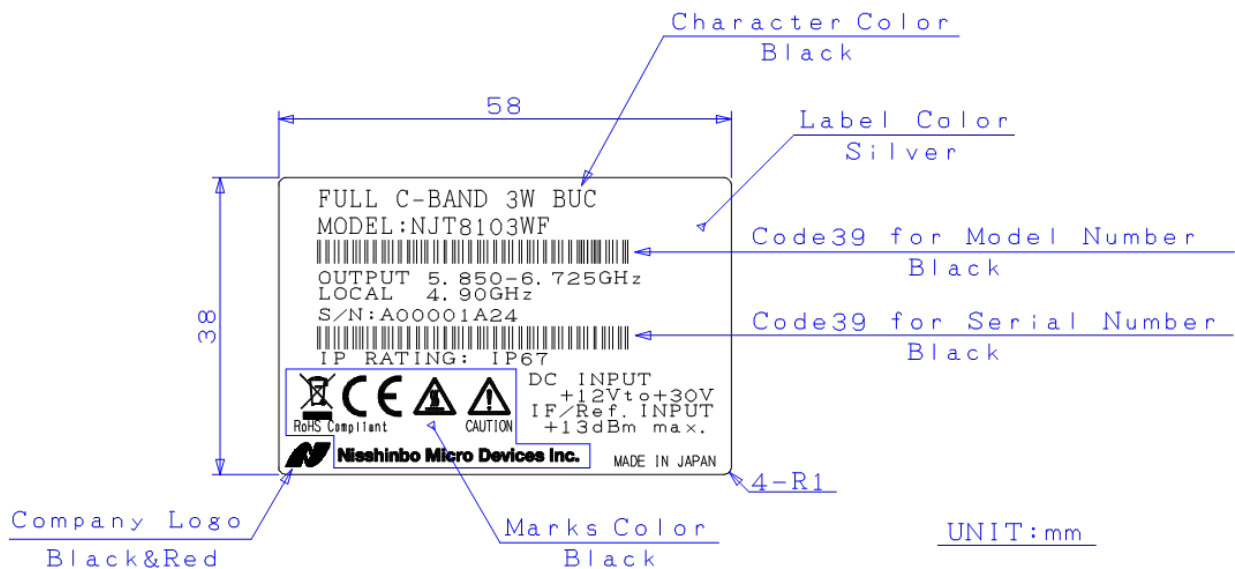

5.2. Definitions

Serial Number (OSSSSSRYM) - ALPHANUMERIC (9 characters)

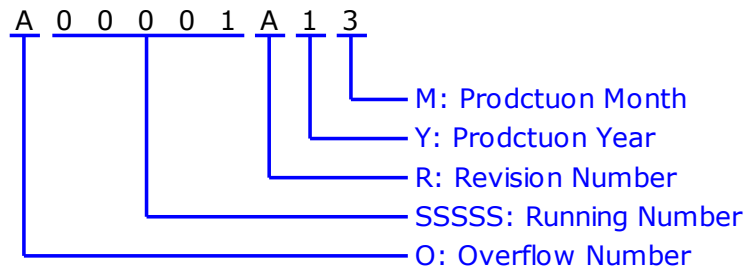

O: Overflow Number - ALPHABET (1 character)

"A" to "T" except "I" and "O", e.g.: A99999 ⇒ B00001

"V" to "Z": Specified Numbers

SSSSS: Running Number - NUMBER (5 digits)

"00001" to "99999"

R: Revision Number - ALPHABET (1 character)

"A" to "Z" except "I", "O", and "U"

Y: Production Year - NUMBER (1 digit)

"0" to "9", Last Digit of Calendar Number

e.g.: 2021:"1", 2022:"2", 2023:"3".....

M: Production Month - ALPHANUMERIC (9 characters)

"1" to "9", "X" as October, "Y" as November, "Z" as December

* Above Specifications are subject to change without notice.

6. Package

6.1. Individual Package

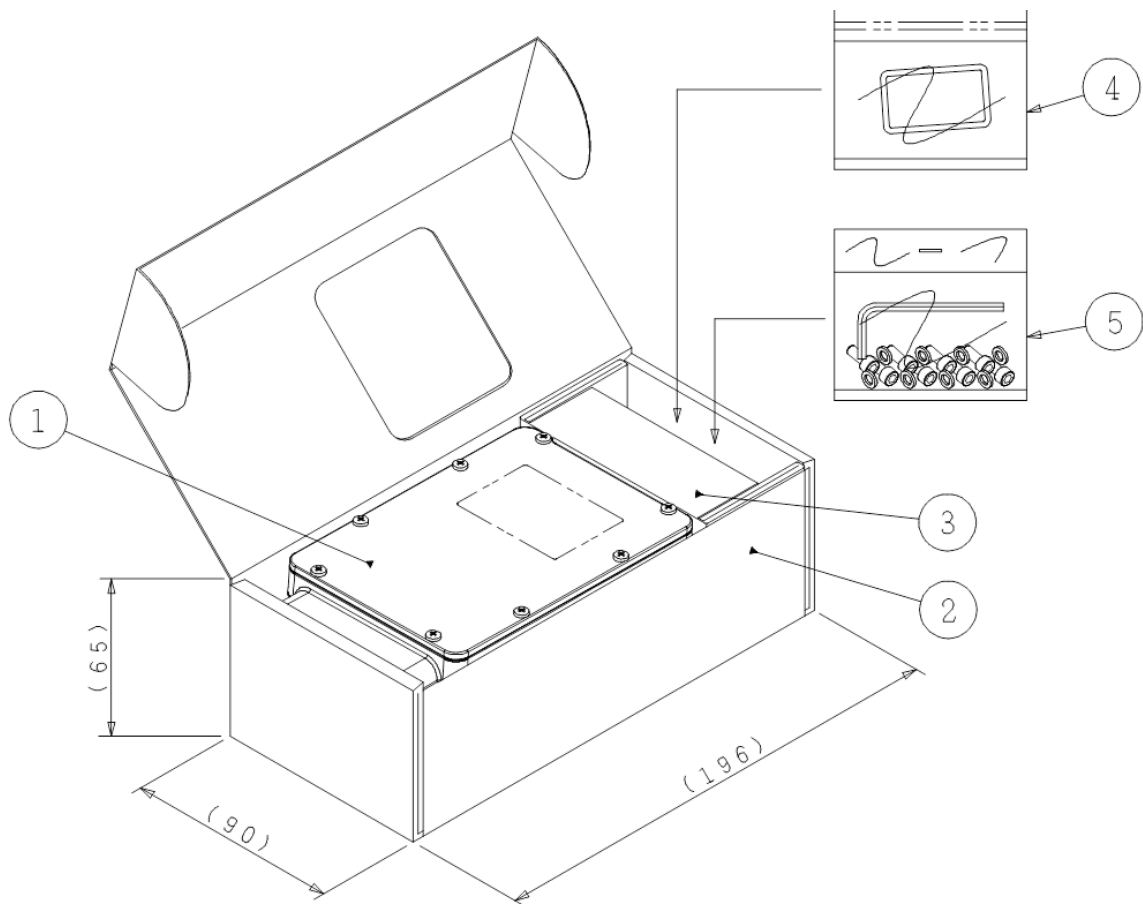

UNIT : mm

- ①: BUC
- ②: Single Wall Corrugated Fiberboard
- ③: Single Wall Corrugated Fiberboard
- ④: Accessories
 - ・O-RING
- ⑤: Accessories
 - ・Hexagon Socket Head Bolts
#10-32UNF×1/2 8pieces(SUS) for Waveguide Flange Holes
 - ・Spring Washers 8pieces(SUS)
 - ・Hexagon Wrench Key

* Above Specifications are subject to change without notice.

6.2. Shipping Package

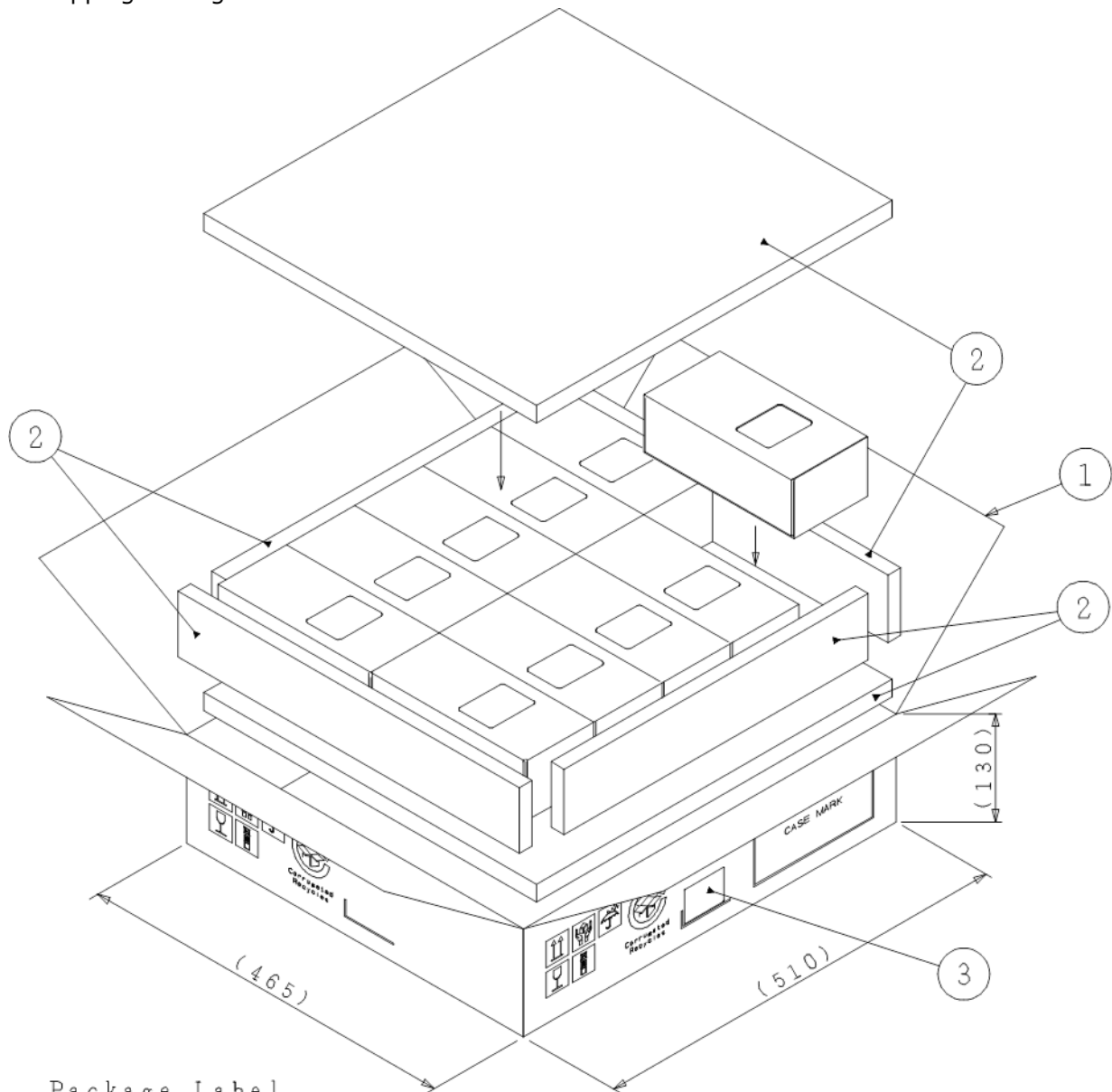

Package Label

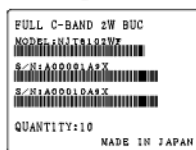

UNIT: mm

Pictorial Marking for Handling of Goods



THIS WAY UP



HANDLE WITH CARE



KEEP DRY



FRAGILE



LAYERS LIMIT: 8

- ①: Double Wall Corrugated Fiberboard
- ②: Polystyrene Foam For Package Cushioning
- ③: Package Label

* Above Specifications are subject to change without notice.

6.3. Enclosed Accessories

- O-ring Gasket, Qty (1), Half-type, for Waveguide Flange
- Wrench Key, Qty (1), #10-32UNF, Hexagon
- Bolts, Qty (8), #10-32UNF L = 1/2", Hexagon Socket Head, SUS, for Waveguide Flange
- Spring Washers, Qty (8), SUS

* Above Specifications are subject to change without notice.

7. Handling Precautions

7.1. DANGER



This statement indicates an imminently hazardous situation which, if not avoided, will result in death or serious injury.

Items	Description
Input Voltage	Only input a DC voltage within the range indicated in specifications. <u>Do</u> operate with the input voltage range between +12 and +30 V DC power. When applying higher voltage than specifications (+30 V as maximum voltage in DC power requirement), it will not only cause this unit failure, but it may also result in <u>electric shock</u> and <u>fire</u> .
Disassembling	<u>Do not</u> disassemble the unit. Disassembling will not only cause this unit failure, but it may also result in <u>electric shock</u> .

7.2. WARNING



This statement indicates a potentially hazardous situation which, if not avoided, could result in death or serious injury.

Items	Description
RF Radiation	A radiation hazard exists if this unit is operated with its RF signal output unterminated. <u>Do not</u> operate this unit without a load or termination attached to the RF signal output.
Hot Surface	Whole of body and heat sink is hot when this unit is powered, and even after power is disconnected until it is cooled down. <u>Do not</u> touch hot surface to avoid a burn hazard.

* Above Specifications are subject to change without notice.

7.3. CAUTION



This statement indicates a potentially hazardous situation which, if not avoided, could result in minor or moderate injury. The statement may also be used to indicate other unsafe practices or risks of property damage.

Items	Description
Disposal	This unit contains gallium arsenide (GaAs), classified as a harmful substance. To avoid danger, <u>do not</u> incinerate, crush, or chemically treat the unit in such a way that gases or dust are released. When disposing the unit, comply with all applicable laws and regulations and do not treat it as general industrial waste or household waste.

7.4. NOTE



This statement is used to notify of installation, operation, or maintenance information that is important, but not hazard-related.

Items	Description
Mounting	<u>Do not</u> block fins of this unit to keep the heat dissipation performance. Normally the unit should be mounted with long fins face up.
Grounding	To reduce the risk of damage or broken by lightning surge, the unit should be grounded by connecting the ground wire.
Torque Management	<u>Do not</u> tighten with excessive torque when attaching screws/bolts and connectors. The following value as tighten torque is recommended. <ul style="list-style-type: none"> ■ Screws/Bolts - M4: 1.52 ± 0.152 N·m #10-32UNF: 2.39 to 2.91 N·m ■ IF Connector (N-type / F-type): 0.68 to 1.13 N·m (3.92 N·m as maximum allowable torque. When over this torque, connector may be damaged.)
Weatherproof	The unit mounted in outdoor should be conducted with adequately weatherproof procedure. Do seal all of cable connection points from the connector to the cable sheath by usage of self-amalgamating tape. Ensure the waveguide connection is properly assembled with the supplied o-ring gasket as accessories. The o-ring gasket is half-type and it is assumed to connect the unit to a flat waveguide flange (non-grooved waveguide flange).
Input Voltage	<u>Do</u> operate with the input voltage range between +12 and +30 V DC power. Avoid applying more than the maximum voltage in this range (including ripple voltage) under any conditions.

* Above Specifications are subject to change without notice.

Items	Description
Input IF Signal Power	<u>Do not</u> supply the input IF signal over the maximum level (+13 dBm), which is indicated on the product label.
Input 10MHz Signal Power	The 10 MHz reference signal should be supplied with the range between -5 and +5 dBm with sine-wave for correctly operation. <u>Do not</u> supply the signal level of more than +13 dBm, which is indicated on the product label.
High Temperature Operation	It may cause damage and/or degradation of reliability / lifetime to operate the unit in a condition where the ambient temperature exceeds the maximum value, <u>+60 °C</u> , at operating temperature described in the specifications.
Vibration / Shock	When vibration and/or shock impact exceeding the conditions described in the specifications is applied, internal parts may be damaged.
Warranty	The unit is covered by a warranty for one(1) year following delivery unless otherwise stipulated in the contract or delivery conditions. Repairs may be possible under payment of charge even for the unit whose warranty period has expired. Opening, removing, disassembling and modifying any parts and components (including the product label, sealing tape and screws) without fan equipment will immediately void the warranty. In any case, the unit of invalid warranty cannot be repaired.

* Above Specifications are subject to change without notice.

8. Instructions Manual

8.1. Descriptions

This section describes the information of connectors and etc.

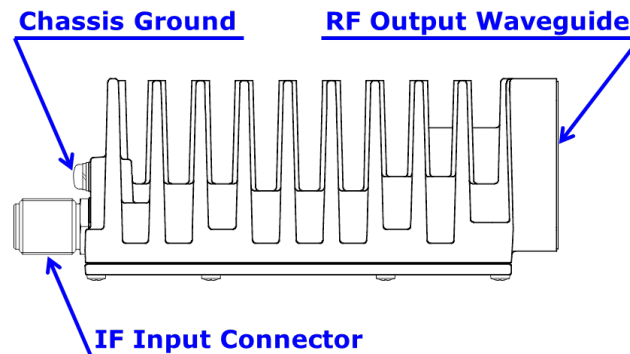

Items	Description	Purpose
Chassis Ground	M4 Screw	Common chassis ground / frame ground.
RF Output Waveguide	Waveguide: WR-137 Flange: CPR-137G (with Groove)	The BUC transmits an RF signal of C-band (5.85 to 6.425 GHz, 5.85 to 6.725 GHz, or 6.725 to 7.025 GHz) output with up to 3W (+34.5 dBm) linear as output power @ 1 dB G.C.P. (P1dB) via this waveguide.
IF Input Connector	F-type Female Coaxial Connector, 75 Ohms OR N-type Female Coaxial Connector, 50 Ohms	The BUC inputs an IF signal of L-band (950 to 1,525 MHz, 950 to 1,825 MHz or 965 to 1,265 MHz), and requires to supply +12 to +30 V DC power and a 10 MHz reference signal via this connector.

8.2. Connection and Installation

This section describes basic installation for the BUC.

8.2.1. Mounting Configuration

The Unit can be mounted with OMT or the waveguide filter of the satellite antenna.

When installing the BUC, the following guidelines should be complied:

- ✓ Check factors such as accessibility, cable connection and future expansion on the installation location.
- ✓ Plan for access to connector side of the BUC.
- ✓ Arrange the BUC with the fin face up or side.

! NOTE

- ✓ Do not block fins of this unit to keep the heat dissipation performance.
Normally the BUC should be mounted with long fins face up or side to keep heat dissipation.

* Above Specifications are subject to change without notice.

When mounting with the OMT or the waveguide filter, the following steps should be complied:

Step 1: Verify that the groove on the waveguide flange for a gasket is clean.

The enclosed gasket as accessories is half-type and it is assumed to connect the BUC to a flat waveguide flange (non-grooved waveguide flange). Insert the gasket the groove as shown in the figure on the right.

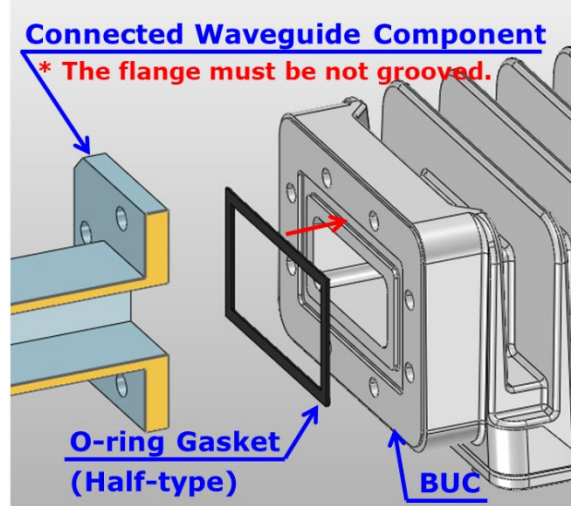

Step 2: Secure the OMT or the filter to the BUC by tightening the enclosed hexagon socket head bolts (#10-32UNF L = 1/2") with 2.39 to 2.91 N·m torque as shown in the figure below, when the thickness of the flange of the OMT or filter assumed to be 4 to 7 mm. The enclosed washers as accessory must be inserted to bolts before tightening bolts.

is

When the thickness is exceed 7 mm, the appropriate length screws or bolts based should be prepared on the table on the right.

Flange Thickness of OMT/Filter	Screw Length
4 to 7 mm [0.15" to 0.275"]	1/2"
7 to 10 mm [0.275" to 0.4"]	5/8"
10 to 13 mm [0.375" to 0.525"]	3/4"

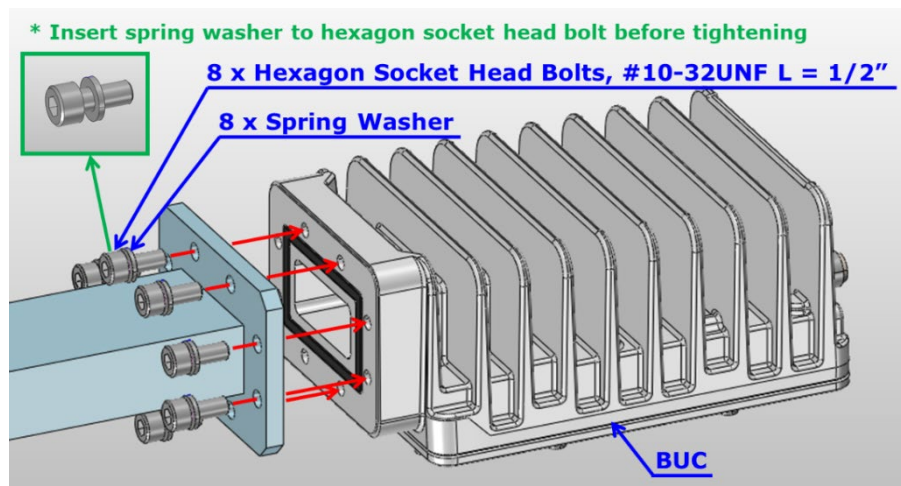

! NOTE

- ✓ The BUC must be adequately weatherproofed to place in outdoor. Ensure that the waveguide joint is properly sealed with the enclosed o-ring gasket.

* Above Specifications are subject to change without notice.

8.2.2. Connecting Coaxial Cable

The BUC is connected the modem with a coaxial cable, and requires to supply +12 to +30 V DC power and a 10 MHz reference signal from the modem.

The connection of coaxial cable should be complied with the following steps:

Step 1: Connect the coaxial cable with the N or F-type male connectors to the coaxial connector equipped with the BUC which is shown in the figure on the right below under 0.68 to 1.13 N·m tighten torque.

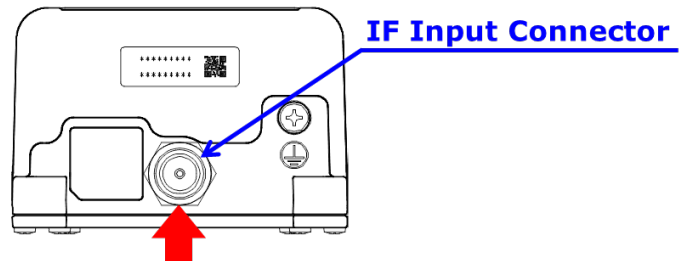

Connect the coaxial cable, and supplied the DC Power and 10MHz reference signal from modem.

Step 2: Use self-amalgamating tape to seal connector and cable entry points from the connector to the cable sheath.

Do not power on the modem before finishing all of steps of Connecting Coaxial Cable.

! NOTE

- ✓ The BUC must be adequately weatherproofed to place in outdoor.
Do seal all of cable connection points from the connector to the cable sheath by usage of self-amalgamating tape.

8.2.3. Connecting Ground Wire for Chassis Ground

The BUC can be had the chassis ground of the other equipment (e.g. modem) in common.

Connecting wire for common chassis ground from the chassis ground of the other equipment should be complied with the following step:

Tools Required: #2 Phillips screwdriver

Step: Connect the ground wire from earth ground or chassis ground of other equipment to the chassis ground with M4 x 6 mm Philips pan head screw under 1.52 ± 0.152 N·m tighten torque.

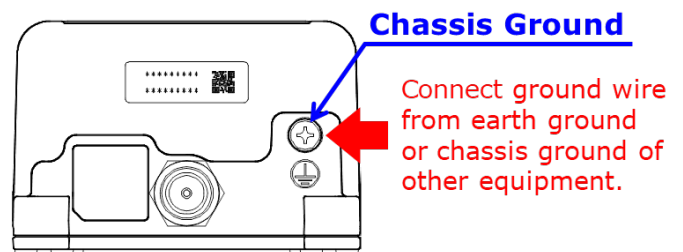

! NOTE

- ✓ To reduce the risk of damage or broken by lightning surge, the unit should be grounded by connecting the ground wire.

* Above Specifications are subject to change without notice.

8.2.4. Start-up

Start-up will be immediately performed with the following step:

Step: Power on the modem and supply the DC voltage and 10 MHz reference from modem.



DANGER

- ✓ Only input a DC voltage within the range indicated in specifications.
Do operate with the input voltage range between +12 and +30 V DC power.
When applying higher voltage than specifications (+30 V as maximum voltage in DC power requirement), it will not only cause this unit failure, but it may also result in electric shock and fire.



NOTE

- ✓ The 10 MHz reference signal should be supplied with the range between -5 and +5 dBm with sine-wave for correctly operation.
Do not supply the signal level of more than +13 dBm.
- ✓ Do not power on the modem before finishing all of steps of Connection and Installation.

* Above Specifications are subject to change without notice.