

Diplexer with DC inserter 10 MHz and L-Band

Key features

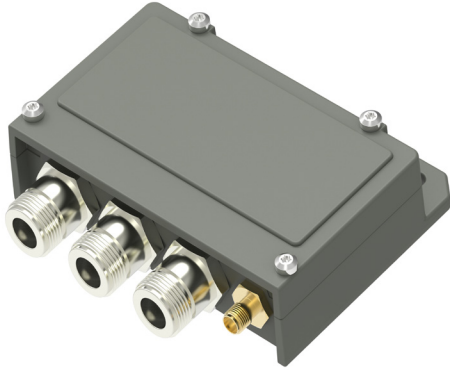

- Low through loss for L-Band
- Outdoor rated (IP 67)
- Wide operating temperature range
- DC/10 MHz/L-Band multiplexing
- Available with F, N or SMA connectors

Description

The L-Band DC Inserter (LNB) / 10 MHz diplexer (LNB or BUC) is used when an external 10 MHz reference signal input is needed for an LNB or BUC. Recommended to use with SMW 10 MHz ref. oscillator or another 10 MHz signal source.

Separate DC insertion (max. 1A) via connector or DC cable (pigtail).

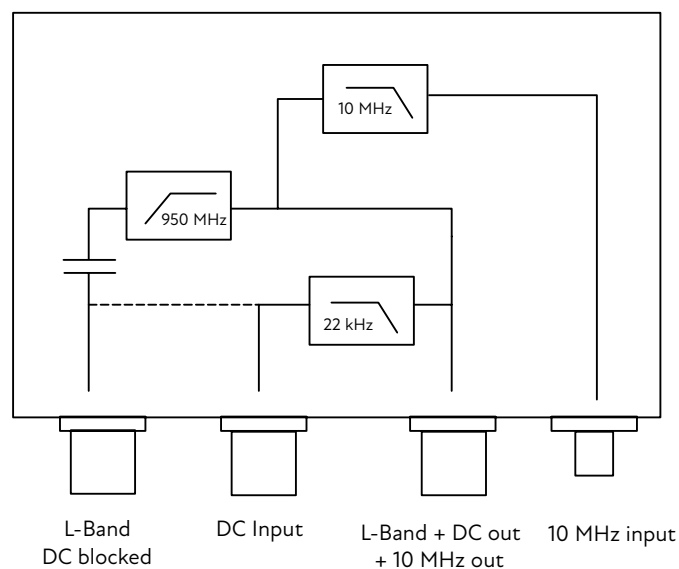

Explore our full product range in this category



Diplexer with DC inserter 10 MHz and L-Band

Technical specifications

GENERAL	L-Band Frequency	950-2150 MHz
	DC input	+13 to +28 V
	Maximum load	1 A
	Insertion loss	1 dB @ 950-2150 MHz max.
	Return loss L-Band	N- and SMA-connector: min. 10dB, typ 15 dB, with F connector min. 8dB, typ. 13 dB (Input/Output)
	Return loss 10 MHz input	> 20 dB
	Return loss 10 MHz output	> 20 dB
	Group delay L-Band	± 1 ns max.
	Dimensions	96 x 28 x 89 mm (N connectors)
	Weight	209 g (F & SMA connectors), 249 g (N connectors)
	Temperature Range	Storage and operating: -40 to +80°C, -40 to +176°F
	MTBF	MTBF as per MIL-HDBK-217F Notice 2: Environmental Condition GF (Ground Fixed): >9000000 hours, Environmental Condition AIC (Airborne, Inhabited, Cargo): >45000000 hours, Quality level: Commercial, Temperature used for MTBF calculation: +35°C Ambient
Ingress protection code	IP 67	
INTERFACES	22 kHz bypass	Through receiver or external source, n/a with DC Block IN or OUT
	10 MHz bypass	Yes, standard
	Input connector (A)	SMA-type 50Ω female, N-type 50Ω female or F-type 75Ω female
	Output Connector (C)	SMA-type 50Ω female, N-type 50Ω female or F-type 75Ω female
	DC connector (B)	SMA-type 50Ω female, N-type 50Ω female, F-type 75Ω female or 2 m pigtail
	10 MHz connector (D)	SMA-type 50Ω female (only this type)

Diplexer with DC inserter 10 MHz and L-Band

Installation example

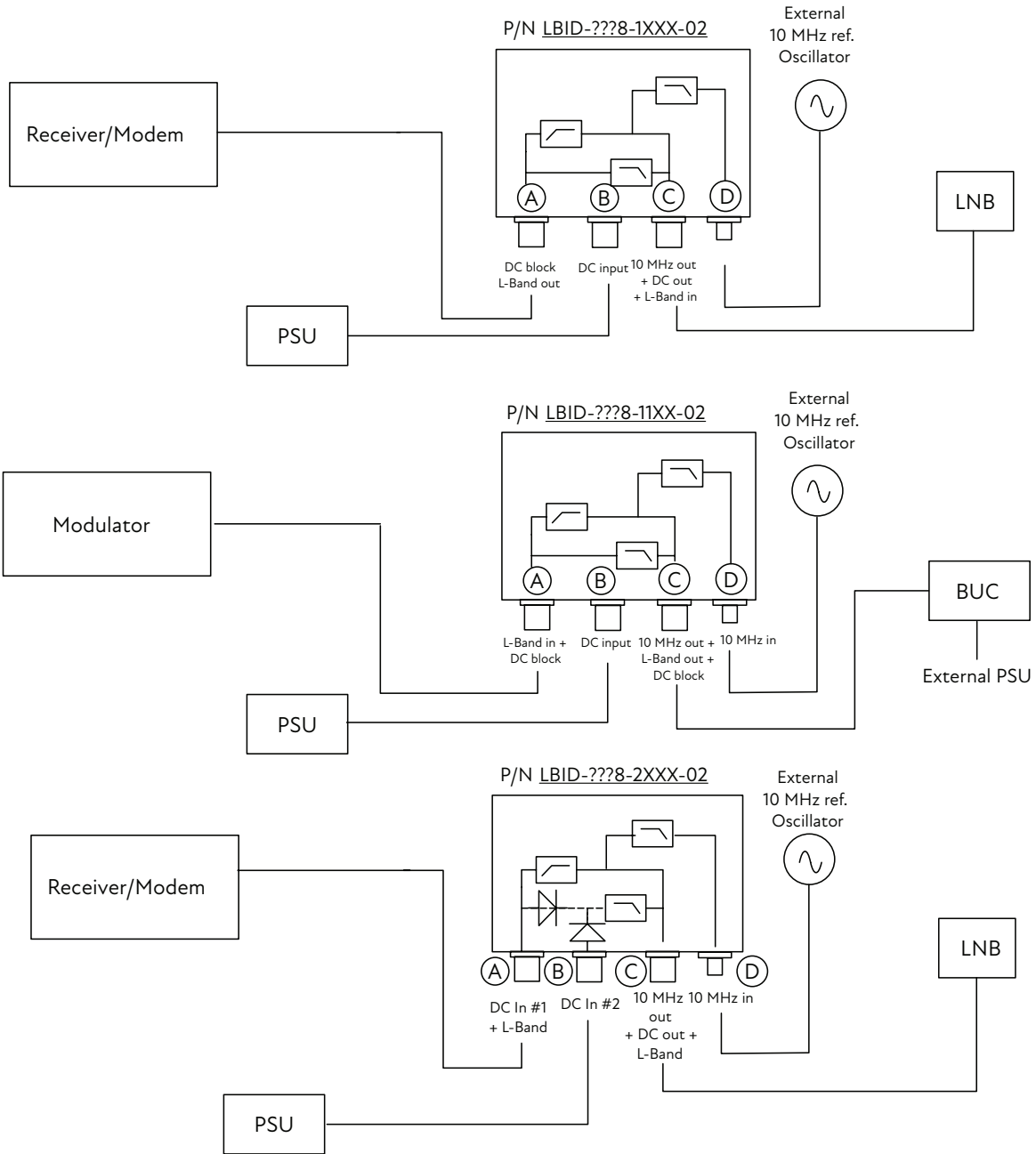

Part number designation for the 10 MHz Diplexer & DC Inserter

Model	Connector A		Sep. DC input B		Connector C		10 MHz in		DC Block A	DC Block C	Future use	Future use	Version
LBID	?		?		?		8	SMA (only)	?	?	X	X	02
0	F	X	No	0	F	8		X	No DC block				
5	N	0	F	5	N			1	DC Block A or C				
8	SMA	5	N	8	SMA			2	DC in A + B, DC out C				
		8	SMA										
		9	Pigtail										

Example: L-Band out + DC Block (N), DC input (Pigtail), L-Band in + 10 MHz + DC out (N), 10 MHz in (SMA) = LBID-5958-1XXX-02

C-BAND

X-BAND

KU-BAND

KA-BAND

Q/V-BAND

RFoFIBER

L-BAND

EXT REF

OTHER

Diplexer with DC inserter 10 MHz and L-Band

Technical Drawing

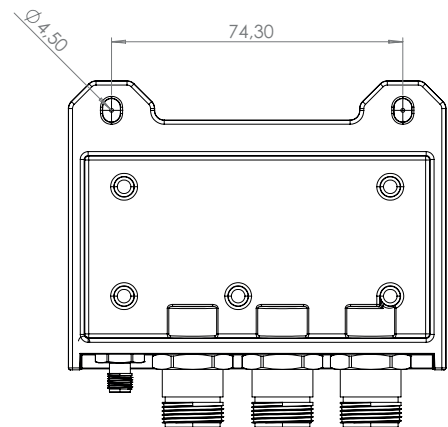
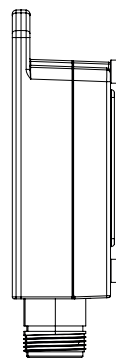
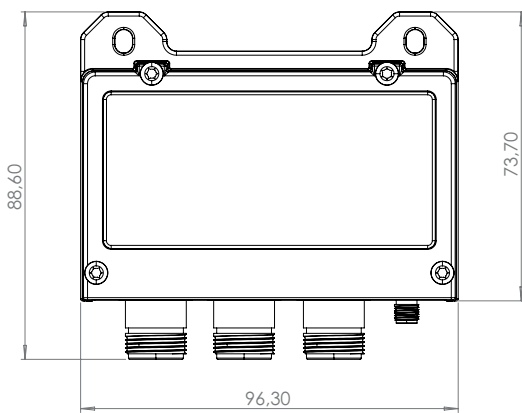
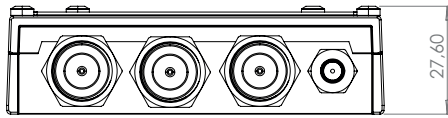

Designed and
Manufactured



Professional Satcom Frequency Converters & Components. All products are fully CE and RoHS compliant and every unit includes full documentation of performance tests and quality control. Please contact sales@smw.se to configure or customize the unit to your needs. Visit smw.se or scan QR code to see our full product range and request a quote.

