

16W / 20W 25W X-Band BUC/SSPB Second Generation GaN Technology

SSPBg-210X™ series

Designed to meet MIL-STD-188-164A



Features

- Up-converts an L-Band input frequency 950 – 1450 MHz to the X-Band frequency of 7.9 – 8.4 GHz
- Rated Output Power from 16W to 25W
- Phase-locked local oscillator locks directly to an external 10 MHz reference
- Exceeds IESS 308/309 Phase/Noise requirements by 3 dB
- Robust, weatherproof package
- Protection against thermal runaway and out-of-lock conditions
- Designed to meet MIL-STD-188-164A

Overview

The SSPBg-210X series are hub-mount up-converter transmitters, using GaN Technology, operating in the X-Band. The SSPBg-210X is an integrated unit, complete with power supply, phase-locked oscillator, mixer, filter and cooling mechanism. Intended for outdoor operation, the SSPBg-210X provides the utmost in convenience and efficiency. Other SSPBs are also available for higher powers or for operation at other up-link frequencies.

The hub-mount SSPBg-210X is constructed in a compact cooling enclosure for outdoor operation. The units are weatherproof. They are smallest fully integrated units on the market today.

The design of these units is based on Advantech Wireless' industry proven reliable solid-state high power amplifiers. Built-in design features result in a product with exceptional linearity and operating efficiency. The use of high efficiency power supply and conservative thermal design contribute to the trouble-free operation of the unit

Accessories

- Mounting kit
- Rx Reject filter

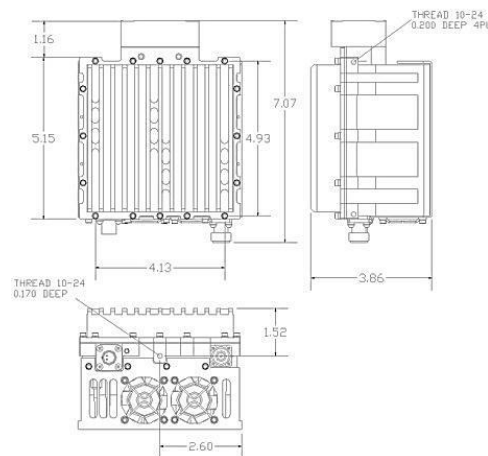
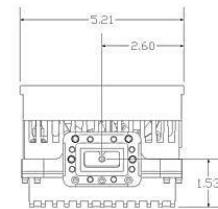

Application

The SSPB's convert an L-Band signal (950 - 1450 MHz) to the X-band frequency of 7.9 – 8.4 GHz. Designed for X-Band satellite up-link applications, the SSPBg-210X series are fully integrated units with up to 25W output power designed for mounting outdoors, near the hub of an antenna.

The size and weight of this very compact design makes it especially attractive for man-pack terminal applications. X-Band SSPBs are available in output power of up to 1000W

16W / 20W 25W X-Band BUC/SSPB Second Generation GaN Technology

Technical Specifications				
Electrical Characteristics		16W	20W	25W
Rated Output power		+42.0 dBm typ.	+43.0 dBm typ.	+44.0 dBm typ.
Linear Output power		+38.0 dBm min.	+39.0 dBm min.	+40.0 dBm min.
Conversion gain min.		+63 dB		
Input /Output frequency range		950-1450 MHz/X-Band 7.9 – 8.4 GHz		
Input Level		-22 dBm for rated output power		
Gain flatness		3.0 dB p-p, typical over 500 MHz, 1.0 dB p-p /40 MHz		
Gain variation over temperature		3.0 dB p-p max over full operating range		
Input VSWR, in-band		1.5: 1		
Output VSWR		1.5: 1		
Input impedance		50 Ω		
Noise Power Density in Rx Band		-110 dBm/Hz max without external Rx Reject Filter		
Spurious at rated power		-55 dBc, max		
AM/PM conversion		1°/dB at linear power		
Spectrum Regrowth		-25 dBc, max at linear output power @ 1.0 symbol rate for QPSK/OPQSK/8PSK modulation		
Local Oscillator frequency (LO)		6.950 GHz		
LO leakage		-20 dBm max		
Phase noise		-55 dBc/Hz at 10Hz	-65 dBc/Hz at 100Hz	
		-73 dBc/Hz at 1000Hz	-83 dBc/Hz at 10 kHz	
		-105 dBc/Hz at 100 kHz	-110 dBc/Hz at 1 MHz	
Integrated (SSB) Phase Noise		2° RMS typical		
Group Delay (over any 40 MHz):	Linear	0.03 ns /MHz, max		
	Parabolic	0.01 ns/MHz ² , max		
	Ripple	1 nsec p-p, max		
External Reference				
Reference frequency		10 MHz		
Recommended reference frequency phase noise		-115 dBc/Hz at 10 Hz	-150 dBc/Hz at 10 kHz	
		-135 dBc/Hz at 100 Hz	-160 dBc/Hz at 100 kHz	
		-148 dBc/Hz at 1000 Hz		
Reference frequency level		0 dBm ± 5 dB		
Power Requirements				
Supply voltage		18 V to 75 V DC via L-band connector		
Power consumption (nominal)		95W		115W
Mechanical Characteristics				
Cooling		Mini-fan		
Dimensions (L x W x H)		17.95 x 13.23 x 9.8 cm (7.07" x 5.21" x 3.86")		
Weight		2.5 kg (5.5 lbs)		
Finish		White (option NATO Green)		
Interfaces:		RF input Type N (F)		RF output CPR112 grooved / Type N (F) optional
Environmental Conditions				
Temperature:	Operating	-30°C to +55°C option -40°C to +55°C		
	Storage	-55°C to +85°C		
Humidity		100%, condensing		
Altitude		10,000' AMSL, de-rated 2°C/1,000' from AMSL		

Ref.: PB-SSPBg-2G-X-16W-20W-25W-18145

NORTH AMERICA

USA
info.usa@advantechwireless.com

CANADA
Info.canada@advantechwireless.com

EUROPE

UNITED KINGDOM
info.uk@advantechwireless.com

RUSSIA & CIS
info.russia@advantechwireless.com

SOUTH AMERICA

info.latam@advantechwireless.com

BRAZIL
info.brazil@advantechwireless.com

ASIA

info.asia@advantechwireless.com

INDIA
info.india@advantechwireless.com