

C-Band Redundant LNA Systems

LRC-1000 Series

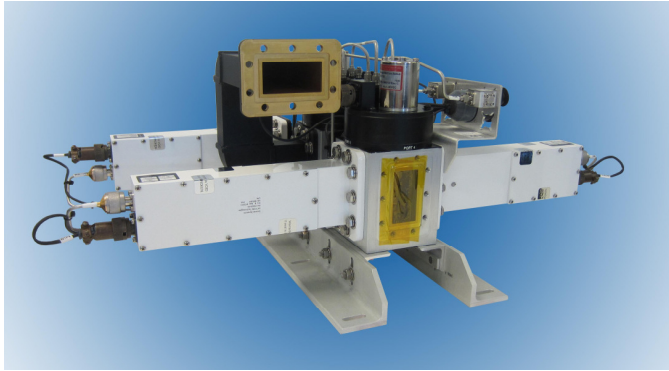

Typical C-Band 1:2 LNA Plate Assembly

Plate Assembly Features

- LC-4000 Series C-band Low Noise Amplifiers (LNAs)
- High quality dual waveguide/coaxial switches
- Manual override
- Waveguide input flanges
- Output coaxial isolators standard
- Transmit reject filter(s), input crossguide coupler(s), output coax couplers, and offline I/O options available

Redundancy Controller Features

- 10/100 Base T Ethernet network interface
- Supports SNMP v1, v2c, and v3
- Rack-mount chassis, 19" wide, 1¾" (1 RU) high
- Dual, redundant power supplies
- Manual or automatic operation
- Monitors unit currents, external alarms, or both
- Automatically switches RF path to standby unit when unit failure occurs
- User-selectable RS-232/-422/-485 serial I/O M&C interface
- Parallel I/O M&C interface
- Menu-driven user configuration of all options
- Front panel graphically depicts switch positions and unit status
- Worldwide universal AC input capability standard; consult factory for DC prime power
- Audible alarm
- CE certified and RoHS compliant; EAR 99

Introduction

Redundant LNA systems minimize system downtime due to LNA failure by providing a spare LNA and an automatic means of switching to the spare upon failure of a primary LNA. A 1:1 system provides one spare LNA for one primary LNA. A 1:2 system provides a spare LNA for either of two primary LNAs. The systems consist of an outdoor plate assembly which mounts at the antenna hub, an indoor control panel and interconnecting control cable.

System Block Diagrams

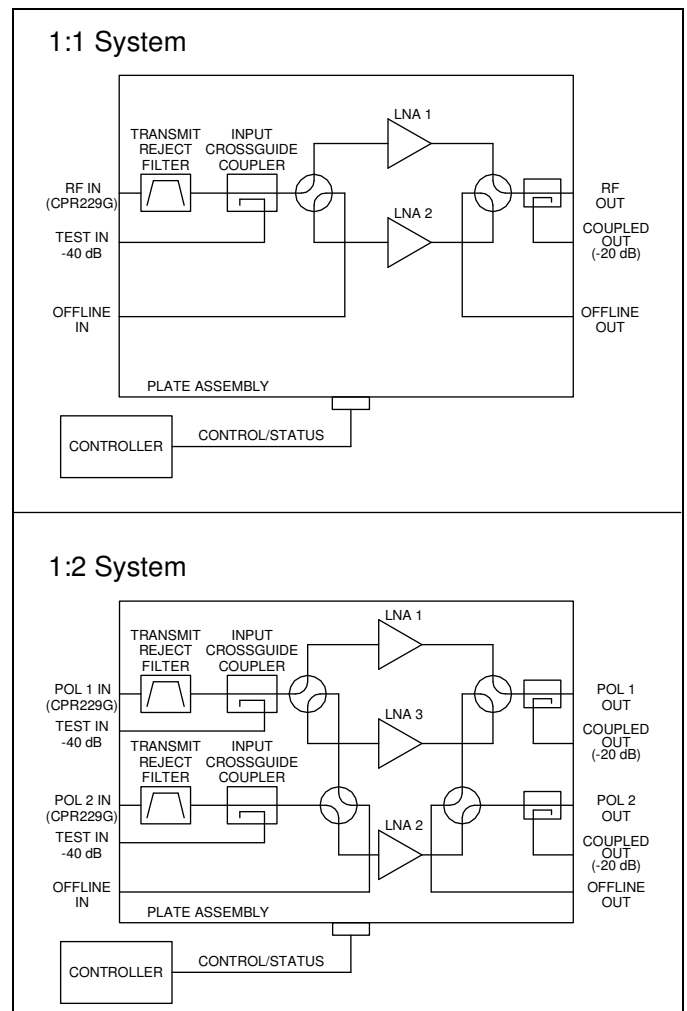

System Specifications *

Parameter	Notes	Min.	Nom./Typ. †	Max.	Units
Frequency Range	Band "C"	3.6		4.2	GHz
	Band "D"	3.4		4.2	GHz
Noise Temperature, System	At +23 °C Versus temperature		See Table 1 See Table 2		
Gain	Standard LNA	60	63		dB
Gain Match	Between LNAs			1	dB
Gain Flatness	Full band Per 40 MHz			±0.5	dB
				±0.2	dB
Gain Stability	Per day, constant temp Versus temperature		-0.05	±0.2	dB dB/°C
VSWR	Input, standard		1.20	1.25	:1
	Input, with system option A or B, Tx filter		1.25	1.30	:1
	Output		1.20	1.25	:1
Power Output at 1 dB Compression (P _{1 dB})	Standard LNA	+10	+13		dBm
	LNA with Option 2	+18	+20		dBm
	LNA with Option 2 & system option D, output couplers	+17	+19		dBm
Third Order Output Intercept Point (OIP ₃)	Standard LNA	+20	+23		dBm
	LNA with Option 2	+28	+30		dBm
	LNA with Option 2 & system option D, output couplers	+27	+29		dBm
AM/PM Conversion	At -5 dBm out			0.05	%dB
Group Delay per 40 MHz	Linear			0.02	ns/MHz
	Parabolic			0.002	ns/MHz ²
	Ripple			0.2	ns p-p
Maximum Input Power	Without damage			0	dBm
Desensitization Threshold for 5.850-6.425 GHz in (Band "C") 5.850-6.725 GHz in (Band "D")	Standard system			-10	dBm
	With system option A or B, Tx filter			+45	dBm
Connectors	RF Input RF Output Offline In/Out, Coupler In/Out		CPR229G Waveguide Flange Type N Female Type N Female		
Temperature Range	Switch Plate Assy	-40		+60	°C

* System specifications depend on choice of LNA and various options. Specifications shown are for a typical system using LC-4000 series LNAs (Specification 2077).

† When there is only one value on a line, the Nom./Typ. column is a nominal value; otherwise it is a typical value. Typical values are intended to illustrate typical performance, but are not guaranteed.

Part Number/Ordering Information

C-Band LNA Systems*	L R C	X
System Type: 1:1 1		
1:2 2		
LNA Frequency: 3.6-4.2 GHz . . . C		
3.4-4.2 GHz . . . D		
LNA Noise Temp.: 30 K 3 0		
35 K 3 5		
40 K 4 0		
45 K 4 5		
LNA Options: +10 dBm output (std.) . . . X		
+20 dBm output 2		
System Options: No filter X		
Tx reject filter, -60 dB		
• 5.850-6.725 GHz reject band . . . A		
• 5.850-6.425 GHz reject band . . . B		
No input coupler(s) X		
Input CG coupler(s), -40 dB . . . C		
No output coupler (s) X		
Output coaxial coupler(s), -20 dB . . . D		
No offline I/O X		
Offline I/O, terminated, with isolator . . . E		
Control Cable: No cable X		
(Standard service) 100 ft. (30 m) 1		
150 ft. (45 m) 2		
200 ft. (60 m) 3		
250 ft. (75 m) 4		

Examples:

1:1 system with 3.6-4.2 GHz, 40 K LNAs, no LNA options, no system options, and 100 ft. cable:

Order Number L R C 1 C 4 0 - X X X X X 1

1:1 system with 3.4-4.2 GHz, 35 K LNAs, no LNA options, Tx Reject filter, CG coupler, and 200 ft. cable:

Order Number L R C 1 D 3 5 - X X A C X X 3

1:2 system with 3.6-4.2 GHz, 45 K LNAs, no LNA options, input CG coupler, output coax coupler, Offline I/O, and 150 ft. cable:

Order Number L R C 2 C 4 5 - X X X C D E 2

1:2 system with 3.4-4.2 GHz, 30 K LNAs with high power output option, input and output couplers, and 150 ft. cable:

Order Number L R C 2 D 3 0 - X 2 X C D X 2

* Note: Consult factory for custom configurations.

Table 1 — Typical System Noise Temperature with Various Options (Add to T_{LNA})

System Configuration:	1:1	1:2		
		Pol. 1	Pol. 2	Standby
Standard Configuration (Add to T _{LNA})	1.5 K	1.5 K	3.0 K	4.5 K
With 40 dB Crossguide Coupler(s)	2.0 K	2.0 K	3.5 K	5.0 K
With Transmit Reject Filter(s), Band "C"	4.5 K	4.5 K	6.0 K	7.5 K
With Transmit Reject Filter(s), Band "D"	9.5 K	9.5 K	11.0 K	12.5 K
With Tx Filter(s) and Coupler(s), Band "C"	5.0 K	5.0 K	6.5 K	8.0 K
With Tx Filter(s) and Coupler(s), Band "D"	10.0 K	10.0 K	11.5 K	13.0 K

Table 2 — Noise Temperature vs. Ambient Temperature

Noise temperature vs. ambient temperature can be found from the equation,

$$NT_2/NT_1 = (T_2/T_1)^n$$

where:

- NT₂ = Noise Temperature at T₂
- NT₁ = Noise Temperature at T₁
- T₂ = Temperature 2 in K
- T₁ = Temperature 1 in K
- n = 1.5 for the LNAs or = 1.0 for passive losses

For the case where T₁ = 296 K (+23 °C), the ratio NT₂/NT₁ is shown in the table below for both LNAs (n = 1.5) and for passive losses (n = 1.0):

Ambient Temperature T ₂ (°C)	n = 1.5 NT ₂ /NT ₁	n = 1.0 NT ₂ /NT ₁
0	0.89	0.92
+23	1.00	1.00
+40	1.09	1.06
+50	1.14	1.09
+60	1.19	1.13

Example: For a 1:1 system with Tx filter, crossguide coupler and 30 K LNAs, T_{LNA} = 30 K at +23 °C and passive losses = 5 K at +23 °C; thus, T_{sys} = 35 K at +23 °C. What is T_{sys} at +50 °C?

From the table, NT₂/NT₁ at 50 °C = 1.14 for the LNAs and 1.09 for the passive losses:
 NT₂ = 1.14 x (30 K) + 1.09 x (5 K) = 34.2 K + 5.4 K = 39.6 K at +50 °C.

Redundant System Controller



1:2 Redundant System Controller, Model RSC12V1-AC

The RSC series redundant system controllers for 1:1 and 1:2 systems directly power the LNAs and monitor the output voltages and currents to detect faults. The RSC

can also monitor external alarm signals or a combination of output currents and external alarm inputs. Upon detecting a fault, the RSC drives an RF transfer switch to activate the spare unit.

The RSC offers monitoring and control of auxiliary RF hardware; remote monitor and control via network, serial interface, or parallel I/O; flexible configuration of system behavior; remote disable of local controls for security; and the ability to detect and report certain failures within the controller itself.

A second RSC can be linked to a primary RSC to provide full system control from an alternate control site. When set up this way, the secondary RSC is referred to as a remote control panel, or RCP. The configuration and settings of the primary RSC are transferred to the RCP, which then mimics its controls and interfaces. This permits system operation from a location that is up to 4000 ft (1200 m) distant from the primary controller.

Controller Specifications

Unit Status Monitor Methods	Controller monitors unit bias current; alarm is generated if current goes outside of allowed tolerance window (LNA or LNB systems). Controller also monitors external alarm inputs (SSPA and other systems) or combinations of both internal unit current and external alarm inputs.
Unit Current Window Width	±5% to ±25% of nominal; user selectable in 5% steps (applies to all monitored unit currents)
Switchover Time	100 ms maximum
Unit Power Outputs	+14.3 to +15.0 Vdc, 700 mA maximum
Switch Drive Outputs	-22 to -28 Vdc, 2 A maximum
External Alarm Inputs	Optionally up to one per unit; require sinking 5 mA at 5 Vdc to negate alarm
Serial I/O Interface	RS-232/RS-422/RS-485 2- or 4-wire; user selection
Parallel I/O Interface	Control inputs: Contact closures to ground; require sinking 20 mA at 15 Vdc Status outputs: Form 'C' dry contacts; 100 Vdc, 0.5 A, 3 W max (resistive load)
Controller Dimensions	19" (483 mm) W x 1.72" (43.7 mm) H x 17.5" (445 mm) D; 7.6 lb (3.4 kg)
Chassis Slides	Standard. Radio relay rack-mount brackets available on request.
Cable Length to Plate Assy	Order cable separately. 100 ft (30 m) to 250 ft (75 m) lengths in 50 ft (15 m) increments are standard; other lengths (up to 500 ft or 150 m) are available by special order.
AC Input (standard)	90-264 Vac, 47–63 Hz, 100 W; Dual AC inputs and dual redundant power supplies.
DC Input (option)	Requires DC-AC inverter. Consult factory.
Temperature Range	Operating: 0 to +50 °C (indoor equipment environment) Storage: -40 to +70 °C
Relative Humidity	Operating: 5% to 95% non-condensing
Altitude	Up to 10,000 ft (3000 m) above mean sea level
Reliability	MTBF: 48,200 hours; MTTR: less than 30 minutes with spares and proper technical person.

Controller Front Panel Controls and Indicators

Unit Status Alarms	LED Indicators glow green when OK, red when a fault is detected.
PS Indicator	Glow red to show fault with either dual redundant power supply.
Panel Test	Pushbutton lights all indicators & tests audible alarm.
RF Switch Pushbuttons and Indicators	<p>Pushbuttons are used to manually switch units. Front panel indicators show which units are on-line. Unit indicators light red to show faulted units.</p> <p>In a typical 1:1 system, Unit 1 is the primary unit and Unit 2 is on standby. In a 1:2 system, Unit 1 is the primary unit for Pol 1 and Unit 2 is the primary unit for Pol 2. Unit 3 is on standby and can be selected for either Pol. In a dual 1:1 system, Unit 1 is the primary unit and Unit 2 is on standby for Pol 1; Unit 3 is the primary and Unit 4 is on standby for Pol 2.</p>
Auto/Manual Switch and Indicators	In Auto mode, a unit failure initiates automatic switchover to the standby unit. In manual mode, the on-line unit can be selected from the front panel or by serial I/O, parallel I/O or network command.
Remote/Local Switch and Indicators	<p>Selects local (front panel) control, or remote control from serial I/O, parallel I/O, or network.</p> <p>An optional second RSC, configured as a Remote Control Panel, provides the means to operate the system from a physically distant, alternate location.</p>

Controller Rear Panel Interfaces

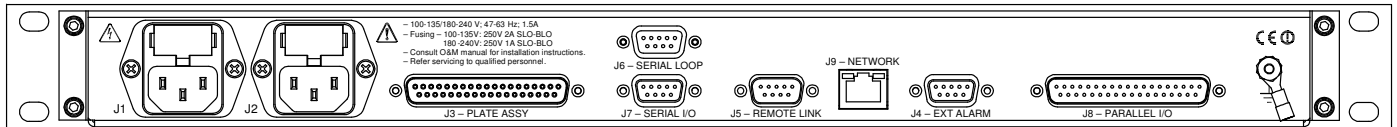

J1, J2 – LINE 1, LINE 2 (IEC 320-C14)	Dual power entry modules contain the AC line input connectors. System can be powered from separate AC lines if desired. Either or both power supplies are capable of operating the system.
J3 – PLATE ASSY (37-pos D, Female)	Cable to plate assembly carries unit power (for line drivers, LNAs or LNBs) and switch drive signals. Order cable separately. Standard lengths are 100' (30 m) to 250' (75 m) in 50' (15 m) increments; other lengths are special order. An adapter cable mates the controller to legacy system cables.
J6 – SERIAL I/O and J7 – SERIAL LOOP (9-pos D Female)	RS-232/RS-422/RS-485 connector for user M&C System. Commands provide monitoring, controlling, and configuration. Interconnect cable lengths to 4000 ft (1200 m) with RS-422 or RS-485. A serial loop connector provides a convenient connection for daisy-chained systems.
J5 – REMOTE LINK (9-pos D Male)	For connection via a proprietary RS-422 link (up to 4000 ft/1200 m) to an optional, second RSC, which duplicates Local control functions at a secondary site.
J9 – NETWORK (RJ-45)	10/100 Base T Ethernet connection port via standard RJ-45 connector. Supports SNMP v1, v2c and v3.
J4 – EXT ALARM (9-pos D Female)	External Alarm inputs. Substitute for or combine with internal unit current monitor alarms. Allows an external signal to indicate unit failure. Unused inputs can be used as status inputs to M&C system.
J8 – PARALLEL I/O (37-pos D Male)	<p>Parallel I/O (discrete logic) connection for limited control and monitoring of the system.</p> <p>Form 'C' relay contact outputs (1:2 system example; others are similar):</p> <ul style="list-style-type: none"> • Unit 1 status • Unit 2 status • Unit 3 status • PS 1 status • PS 2 status • Local/Remote mode • Pol 1: Unit 1 or Unit 3 • Pol 2: Unit 2 or Unit 3 • Auto/Manual mode <p>Control inputs—contact closure to ground (1:2 system example; others are similar):</p> <ul style="list-style-type: none"> • Pol 1 Unit 1 select • Pol 1 Unit 3 select • Pol 2 Unit 2 select • Pol 2 Unit 3 select • Auto/Manual select

1:1 Plate Assembly Outline Drawing, with Various Options Installed

NOTES:

- 1) OUTPUT ISOLATOR INCLUDED WITH STANDARD SYSTEM
- 2) DIMENSIONS ARE IN INCHES AND [MILLIMETERS].
- 3) TRANSMIT REJECT FILTER OPTIONS:

	OPTION A	OPTION B
X	11.00 [279.4]	6.35 [161.3]
Y	26.93 [684.0] MIN. 27.93 [709.4] MAX.	22.28 [565.9] MIN. 23.28 [591.3] MAX.

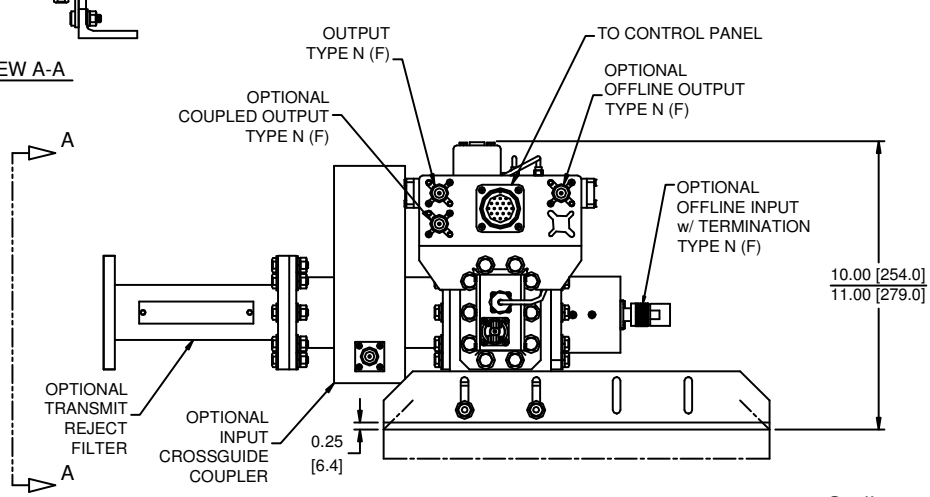
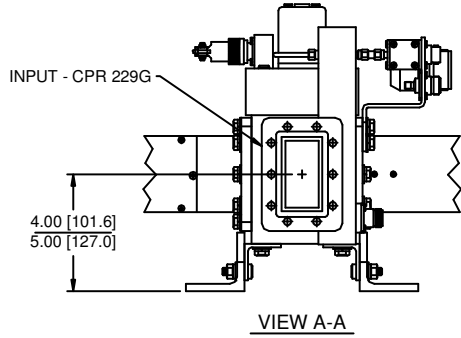
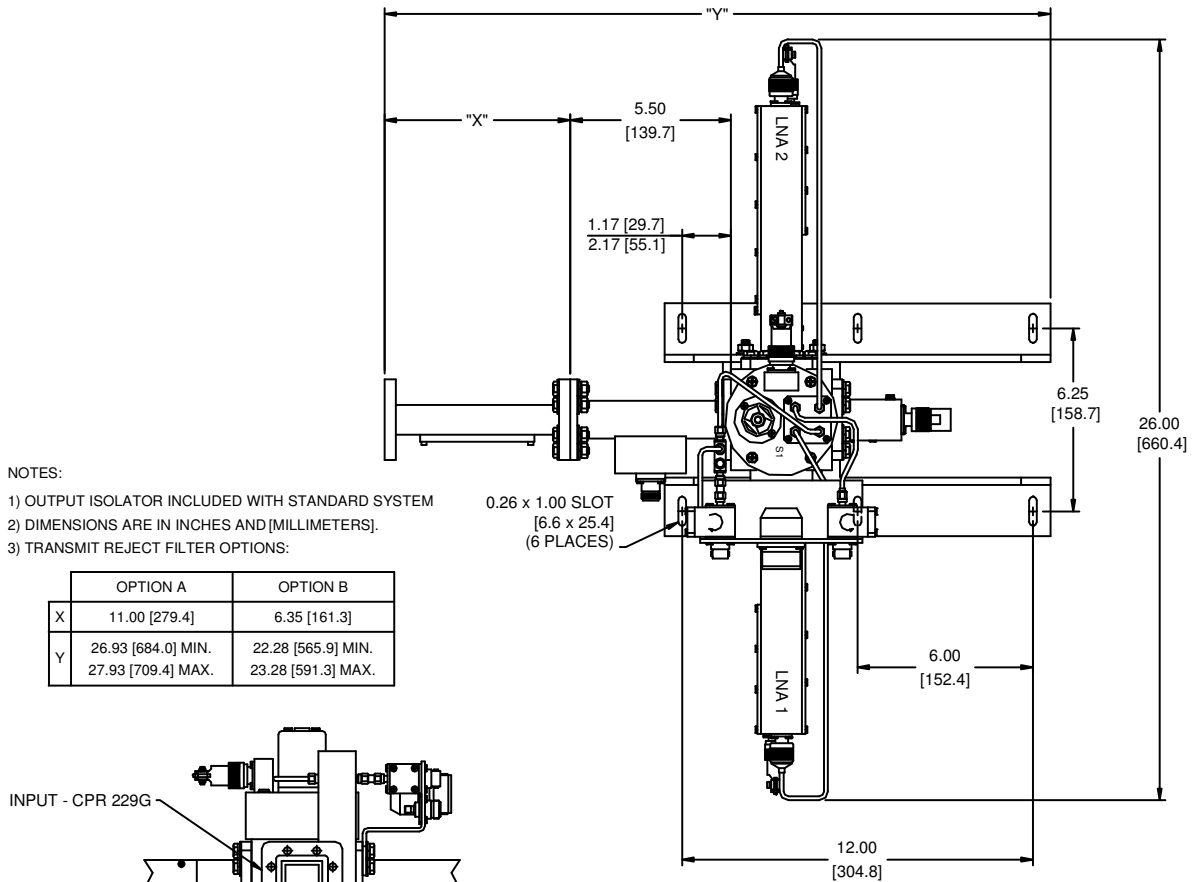

Outline 12668-2

1:2 Plate Assembly Outline Drawing, with Various Options Installed

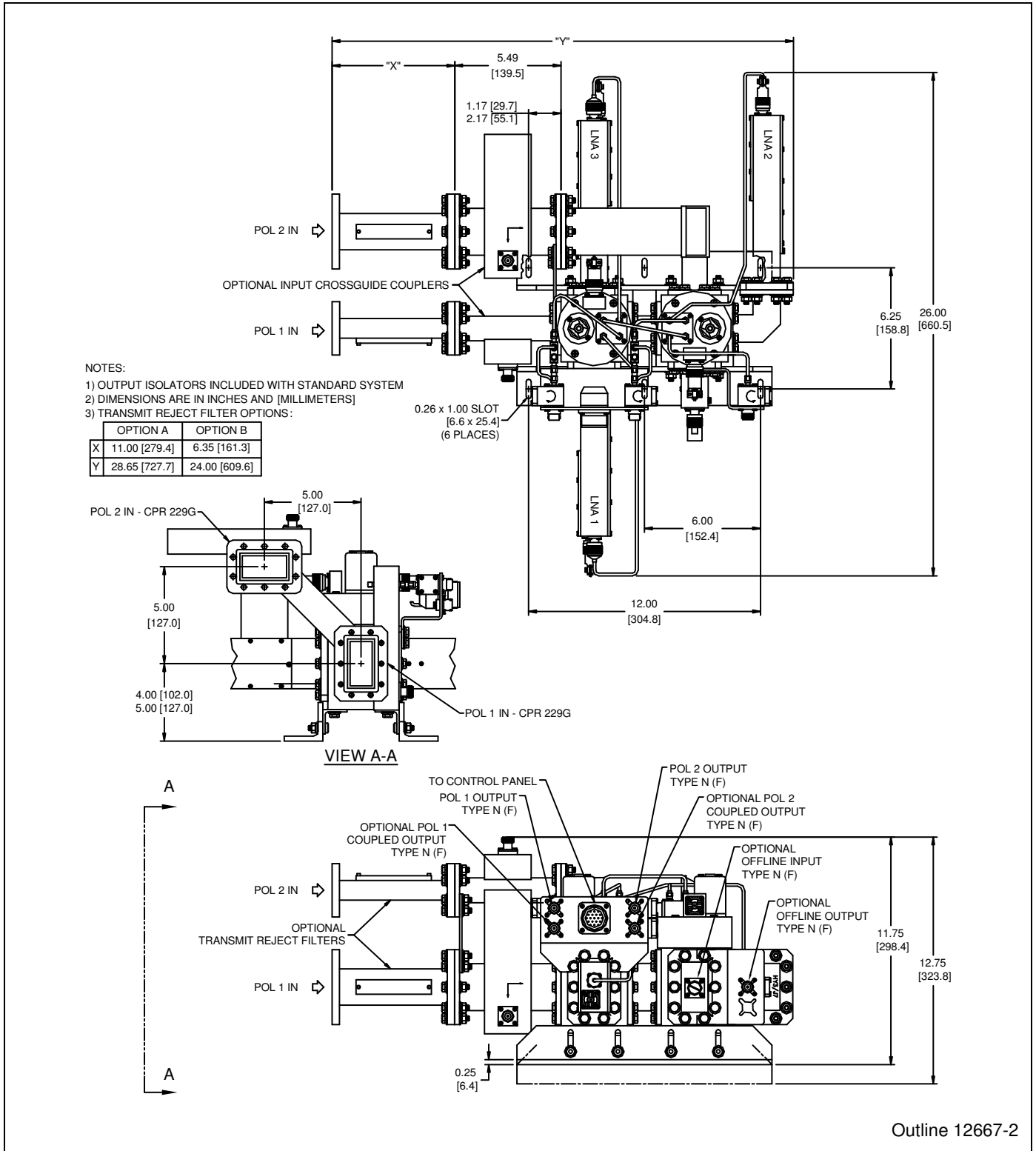



Other Products

- Solid-State Power Amplifiers and SSPA Systems
- Solid-State Power BUCs and SSPB Systems
- Low Noise Amplifiers and LNA Systems
- Low Noise Block Converters and LNB Systems
- Block Up and Block Down Converters
- Synthesized Converters
- Line Drive Amplifiers
- Power Supply Monitors
- Redundant Control Panels for SSPAs, SSPBs, and LNAs

GENERAL DYNAMICS SATCOM Technologies

60 Decibel Road, Suite 200 • State College, PA 16801 USA • Tel. +1-814-238-2700 • FAX +1-814-238-6589
Email: satcom@gd-ms.com • www.gdsatcom.com/electronics.php

11842 Rev. F

© 2015 General Dynamics. All rights reserved. General Dynamics reserves the right to make changes to its products and specifications at any time and without notice. All trademarks indicated as such herein are trademarks of General Dynamics. All other product and service names are the property of their respective owners.