

SPECIFICATIONS

FREQUENCY BAND RX: 3.625-4.200 GHz
TX: 5.850-6.425 GHz

INSERTION LOSS RX: 0.15 dB MAX
TX: 0.20 dB MAX

VSWR RX: 1.20:1 dB MAX
TX: 1.20:1 dB MAX

ISOLATION TX/RX: 70 dB MIN
RX/TX: 70 dB MIN

CROSSPOL : 35 dB MIN

POWER HANDLING : 5KW CW

PRESSURIZATION : SEALED TO 2 PSIG WITH TYPE N CONNECTOR CAPPED OFF

FINISH: INTERIOR
AND FLANGE FACES: CHEM FILMED PER MIL-C-5541C, CLASS 1A
EXTERIOR: WHITE PAINT, COLOR NO. 17875 PER FED-STD-585

REVISIONS			
REV	DESCRIPTION	DATE	APPROVED
G	SEE REVISION RECORD SHEET	02-26-99	

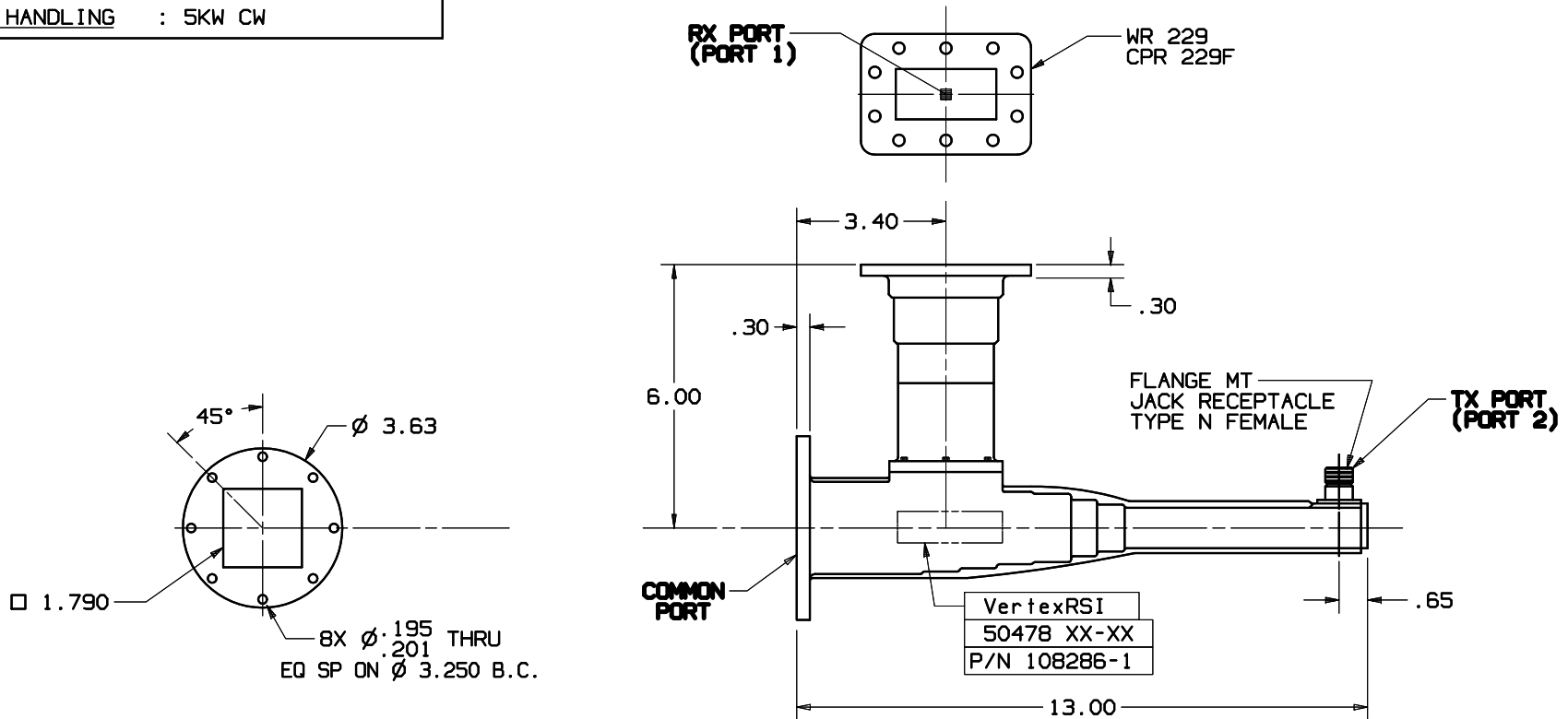

-1 CONFIGURATION

NOTES: UNLESS OTHERWISE SPECIFIED.

<p>UNLESS OTHERWISE SPECIFIED</p> <p>DIMENSIONS ARE IN INCHES</p> <p>TOLERANCES-</p> <table style="width: 100%;"> <tr> <td style="width: 15%;">SURFACE</td> <td style="width: 15%;">.XX</td> <td style="width: 15%;">±.03</td> </tr> <tr> <td></td> <td>.XXX</td> <td>±.004</td> </tr> <tr> <td></td> <td>.XXXX</td> <td>±.0020</td> </tr> </table> <p>✓ ANGLES±</p> <p>MATERIAL CAST ALUMINUM</p> <p>FINISH</p>	SURFACE	.XX	±.03		.XXX	±.004		.XXXX	±.0020	<table style="width: 100%;"> <tr> <th colspan="2">SIGNATURES</th> <th>DATE</th> </tr> <tr> <td>DRAWN:</td> <td>L. TOVALIN</td> <td>01-25-95</td> </tr> <tr> <td>CHECKED:</td> <td>H. SPIELEDER</td> <td>01-25-95</td> </tr> <tr> <td>ENGRG:</td> <td></td> <td></td> </tr> <tr> <td>ENGRG:</td> <td></td> <td></td> </tr> </table> <p>EXPORT CONTROL WARNING: Do not disclose this document or its contents to non-U.S. Citizens or transmit this document or its contents outside the U.S.A. without the written permission of General Dynamics and required U.S. Government approvals</p>	SIGNATURES		DATE	DRAWN:	L. TOVALIN	01-25-95	CHECKED:	H. SPIELEDER	01-25-95	ENGRG:			ENGRG:			<p style="text-align: center;">GENERAL DYNAMICS C4 SYSTEMS VertexRSI™ Torrance Facility 3111 Fujita St., Torrance, CA 90505, (310)539-6704</p> <p style="text-align: center;">C-BAND 2-PORT Rx/Tx, X-POL, TYPE N</p> <table style="width: 100%;"> <tr> <td style="width: 10%;">SIZE</td> <td style="width: 15%;">FSCM NO.</td> <td style="width: 35%;">DRAWING NO.</td> <td style="width: 10%;">REV</td> </tr> <tr> <td>C</td> <td>50478</td> <td>108286</td> <td>G</td> </tr> <tr> <td colspan="3">SCALE: 1/2</td> <td style="text-align: right;">SHEET 1 of 2</td> </tr> </table>	SIZE	FSCM NO.	DRAWING NO.	REV	C	50478	108286	G	SCALE: 1/2			SHEET 1 of 2
SURFACE	.XX	±.03																																				
	.XXX	±.004																																				
	.XXXX	±.0020																																				
SIGNATURES		DATE																																				
DRAWN:	L. TOVALIN	01-25-95																																				
CHECKED:	H. SPIELEDER	01-25-95																																				
ENGRG:																																						
ENGRG:																																						
SIZE	FSCM NO.	DRAWING NO.	REV																																			
C	50478	108286	G																																			
SCALE: 1/2			SHEET 1 of 2																																			