

Ku-band 3W BUC

RF Frequency:

13.75 to 14.5 GHz and 14.0 to 14.5 GHz

Model No. NJT8302 series

RF Frequency : 14.0 to 14.5 GHz / 13.75 to 14.5 GHz
LO Frequency : 13.05 GHz / 12.80 GHz
IF Frequency : 950 to 1,450 MHz / 950 to 1,700 MHz
Output Power @ 1dB G.C.P. :
+34.0 dBm (3W)
IF / Ref. (10MHz) Input :
N-type / F-type, Female Connector
DC Power Input : IF Connector

Specifications

Rev.09 February 3, 2017

Copyright 2017

New Japan Radio Co., Ltd.
Microwave Division

-Notice of Proprietary Information-

Documents and contents are proprietary to New Japan Radio Co., Ltd.
This publication and its contents may not be reproduced or distributed for any other purpose without the written permission of New Japan Radio Co., Ltd.



Caution

1. NJRC strives to produce reliable and high quality microwave components. NJRC's microwave components are intended for specific applications and require proper maintenance and handling. To enhance the performance and service of NJRC's microwave components, the devices, machinery or equipment into which they are integrated should undergo preventative maintenance and inspection at regularly scheduled intervals. Failure to properly maintain equipment and machinery incorporating these products can result in catastrophic system failures.
2. To ensure the highest levels of reliability, NJRC products must always be properly handled. The introduction of external contaminants (e.g. dust, oil or cosmetics) can result in failures of microwave components.
3. NJRC offers a variety of microwave components intended for particular applications. It is important that you select the proper component for your intended application. You may contact NJRC's sales office or sales representatives, if you are uncertain about the products listed in the catalog and the specification sheets.
4. Special care is required in designing devices, machinery or equipment, which demand high levels of reliability. This is particularly important when designing critical components or systems whose foreseeable failure can result in situations that could adversely affect health or safety. In designing such critical devices, equipment or machinery, careful consideration should be given to, amongst other things, their safety design, fail-safe design, back-up and redundancy systems, and diffusion design.
5. The products listed in the catalog and specification sheets may not be appropriate for use in certain equipment where reliability is critical or where the products may be subjected to extreme conditions. You should consult our sales office or sales representatives before using the products in any of the following types of equipment.
 - * Aerospace Equipment
 - * Equipment Used in the Deep Sea
 - * Power Generator Control Equipment (nuclear, steam, hydraulic)
 - * Life Maintenance Medical Equipment
 - * Fire Alarm/Intruder Detector
 - * Vehicle Control Equipment (automobile, airplane, railroad, ship, etc.)
 - * Various Safety Equipment
6. NJRC's products have been designed and tested to function within controlled environmental conditions. Do not use products under conditions that deviate from methods or applications specified in the catalog and specification sheets. Failure to employ NJRC's products in the proper applications can lead to deterioration, destruction or failure of the products. NJRC shall not be responsible for any bodily injury, fires or accidents, property damage or any consequential damages resulting from the misuse or misapplication of its products. **PRODUCTS ARE SOLD WITHOUT WARRANTY OF ANY OF KIND, EITHER EXPRESS OR IMPLIED, INCLUDING BUT NOT LIMITED TO ANY IMPLIED WARRANTY OF MERCHANTABILITY OR FITNESS FOR A PARTICULAR PURPOSE.**
7. The product specifications and descriptions listed in the catalog and specification sheets are subject to change at any time, without notice.

* Above Specifications are subject to change without notice.



Model Number

- Numbering System

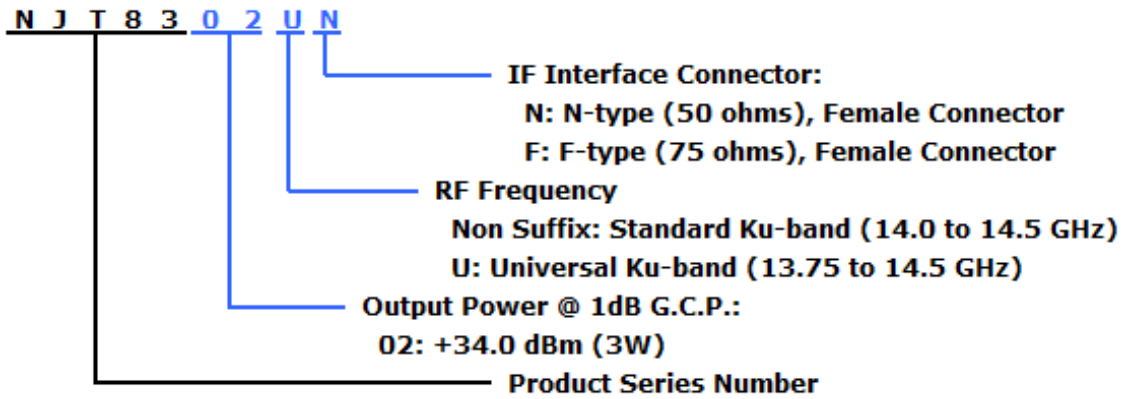

- Line-up

Model No.	RF Frequency	Local Frequency	IF Frequency	Output Power @ P1dB	IF Connector	Power Supply
NJT8302N	14.0 to 14.5GHz (Standard Ku-band)	13.05 GHz	950 to 1,450 MHz	3W Linear (+34dBm min.)	N-type	+12 to +30 V DC Power
NJT8302F					F-type	
NJT8302UN	13.75 to 14.5GHz (Universal Ku-band)	12.80 GHz	950 to 1,700 MHz		N-type	
NJT8302UF					F-type	

* Above Specifications are subject to change without notice.



1. Electrical Specifications

#	Items	Specifications
1-1.	Output Frequency Range	
	<Universal Ku-band>	13.75 to 14.5 GHz
	<Standard Ku-band>	14.0 to 14.5 GHz
1-2.	Input Frequency Range	
	<Universal Ku-band>	950 to 1,700 MHz
	<Standard Ku-band>	950 to 1,450 MHz
1-3.	Maximum IF Input Level (without damage)	+13 dBm max.
1-4.	Conversion Type	Single, fixed L.O.
1-5.	L.O. Frequency	
	<Universal Ku-band>	12.80 GHz
	<Standard Ku-band>	13.05 GHz
1-6.	Frequency Sense	Positive
1-7.	Output Power @ 1dB G.C.P. (P1dB)	+34.0 dBm min. over temperature
1-8.	Linear Gain	58 dB typ. 51 dB min.
1-9.	Gain Variation over frequency @ fixed temperature	
	<Universal Ku-band>	5 dBp-p max. over 750 MHz 2 dBp-p max. over any 36 MHz
	<Standard Ku-band>	5 dBp-p max. over 500 MHz 2 dBp-p max. over any 36 MHz
1-10.	Gain Stability over temperature @ fixed frequency	5 dBp-p max. 2 dBp-p typ.
1-11.	ACPR	-26 dBc typ. @ Pout = +34 dBm
1-12.	Requirement for External Reference [Frequency] [Input Power] [Phase Noise]	10 MHz (sine-wave) -5 to +5 dBm @ Input port -125 dBc/Hz max. @ 100 Hz -135 dBc/Hz max. @ 1 kHz -140 dBc/Hz max. @ 10 kHz
1-13.	L.O. Phase Noise	-60 dBc/Hz max. @ 100 Hz -70 dBc/Hz max. @ 1 kHz -80 dBc/Hz max. @ 10 kHz -90 dBc/Hz max. @ 100 kHz -100 dBc/Hz max. @ 1MHz
1-14.	Spurious @ Pout = +34 dBm [in band] [in receive band] [Out-of-band]	-50 dBc max. @ RF Frequency -70 dBm max. @ 10.95 to 12.75 GHz -50 dBc max.
1-15.	Receive Band Noise Density	
	<Universal Ku-band>	* In case of RF Freq.: 14.0 to 14.5 GHz -156 dBm/Hz max. @10.95 to 12.25 GHz * In case of RF Freq.: 13.75 to 14.0 GHz -156 dBm/Hz max. @10.95 to 12.25 GHz -142 dBm/Hz max. @12.25 to 12.75 GHz
	<Standard Ku-band>	* In case of RF Freq.: 14.0 to 14.5GHz -156 dBm/Hz max. @ 10.95 to 12.75 GHz
1-16.	Noise Figure	18 dB nom., 23 dB max.
1-17.	Input Impedance	
	<N-type Model>	50 ohms nom.
	<F-type Model>	75 ohms nom.

* Above Specifications are subject to change without notice.



#	Items	Specifications
1-18.	Input V.S.W.R.	2 : 1 max.
1-19.	Output V.S.W.R.	2 : 1 max.
1-20.	Output Load VSWR for Non Damage	Infinite : 1
1-21.	DC Power Requirement [Voltage Range] [Power Consumption]	+24 VDC (+12 to +30 VDC) 18 W typ., 23 W max. @ Pout = +34 dBm 15 W max. @ No IF, +25 C 2 W max. @ 10 MHz reference off (Mute on)
1-22.	Mute	Shut off the HPA in case of L.O. unlocked or no 10 MHz reference signal.

2. Mechanical Specifications

#	Items	Specifications
2-1.	Input Interface <N-type Model> <F-type Model>	IF / Ref. / DC Input: N-type female connector, 50 ohms F-type female connector, 75 ohms
2-2.	Output Interface	Waveguide, WR-75 (with Groove)
2-3.	Dimension & Housing	91.55 (L) x 68 (W) x 42.5 (H) mm [3.60" (L) x 2.68" (W) x 1.67" (H)] without interface connectors
2-4.	Weight	350 g max. [0.77 lbs max.]

3. Environmental Specifications

#	Items	Specifications
3-1.	Temperature Range (ambient) [Operating] [Storage]	-40 to +55 °C *1 -40 to +75 °C
3-2.	Humidity	0 to 100 % *2
3-3.	Altitude	15,000 feet
3-4.	Vibration	5 G [49.03 m/s ²] (3 axis, 50 Hz to 2 kHz) 1 mm p-p (3 axis, 5 to 50 Hz)
3-5.	Shock	30 G [294.20 m/s ²] (3 axis)
3-6.	Waterproof / Dustproof (IP Code)	IP 67
3-7.	Regulations	EU Directive (CE Marking) EMC (2014/30/EC) RoHS (2011/65/EU) Safety: EN60950-1
3-8.	Comply with RoHS (Restricting the use of Hazardous Substances) directives	

*1: Conditioned on connection with OMT and TRF.

*2: Premised on connection with the hermetically-sealed OMT and Feed horn.

* Above Specifications are subject to change without notice.

4. Outline Drawing

- N-type Model

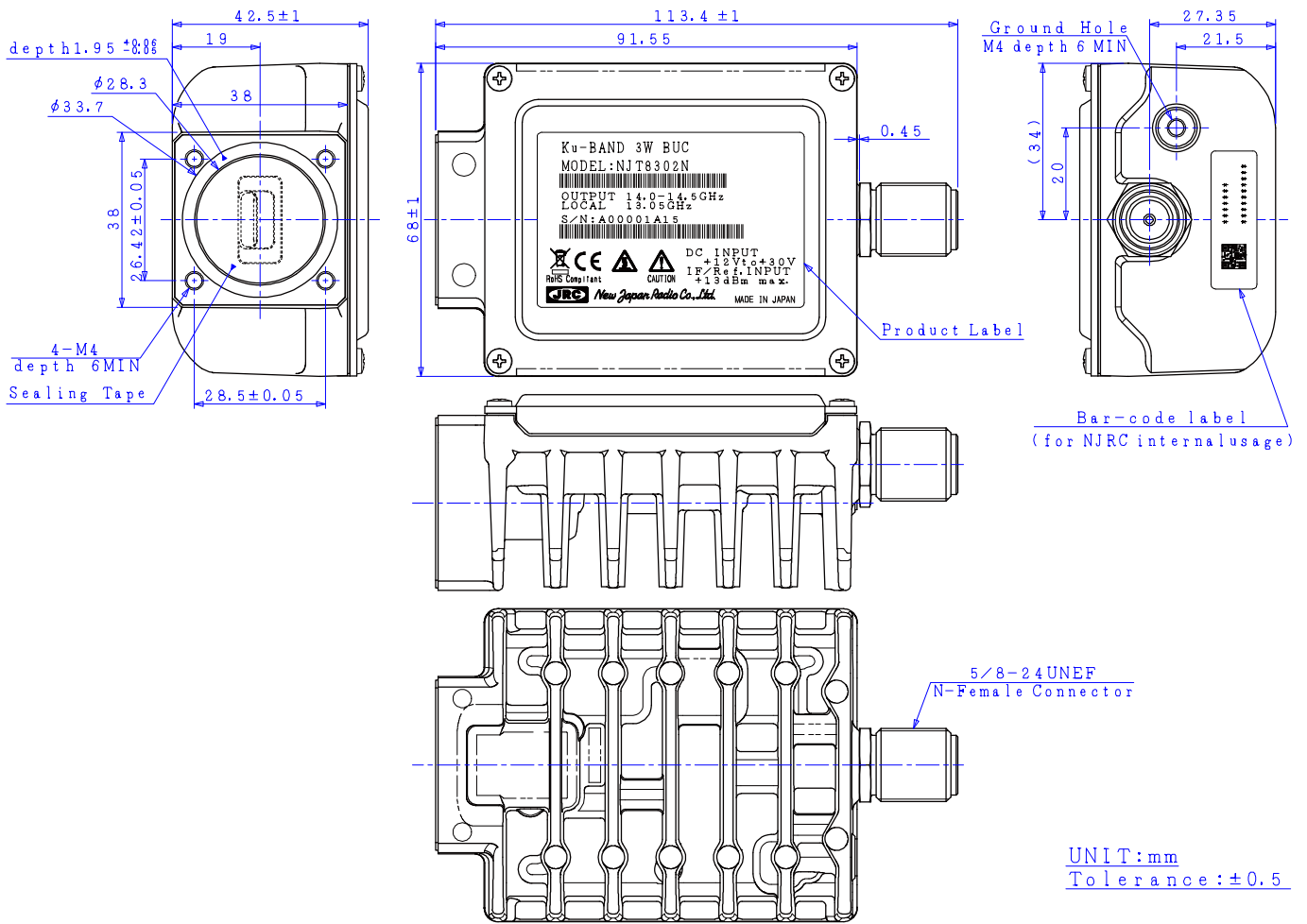

Caution: DO NOT remove the sealing tape on the waveguide. If the sealing tape is removed, it may lose the performance of waterproof.

* Above Specifications are subject to change without notice.

● F-type Model

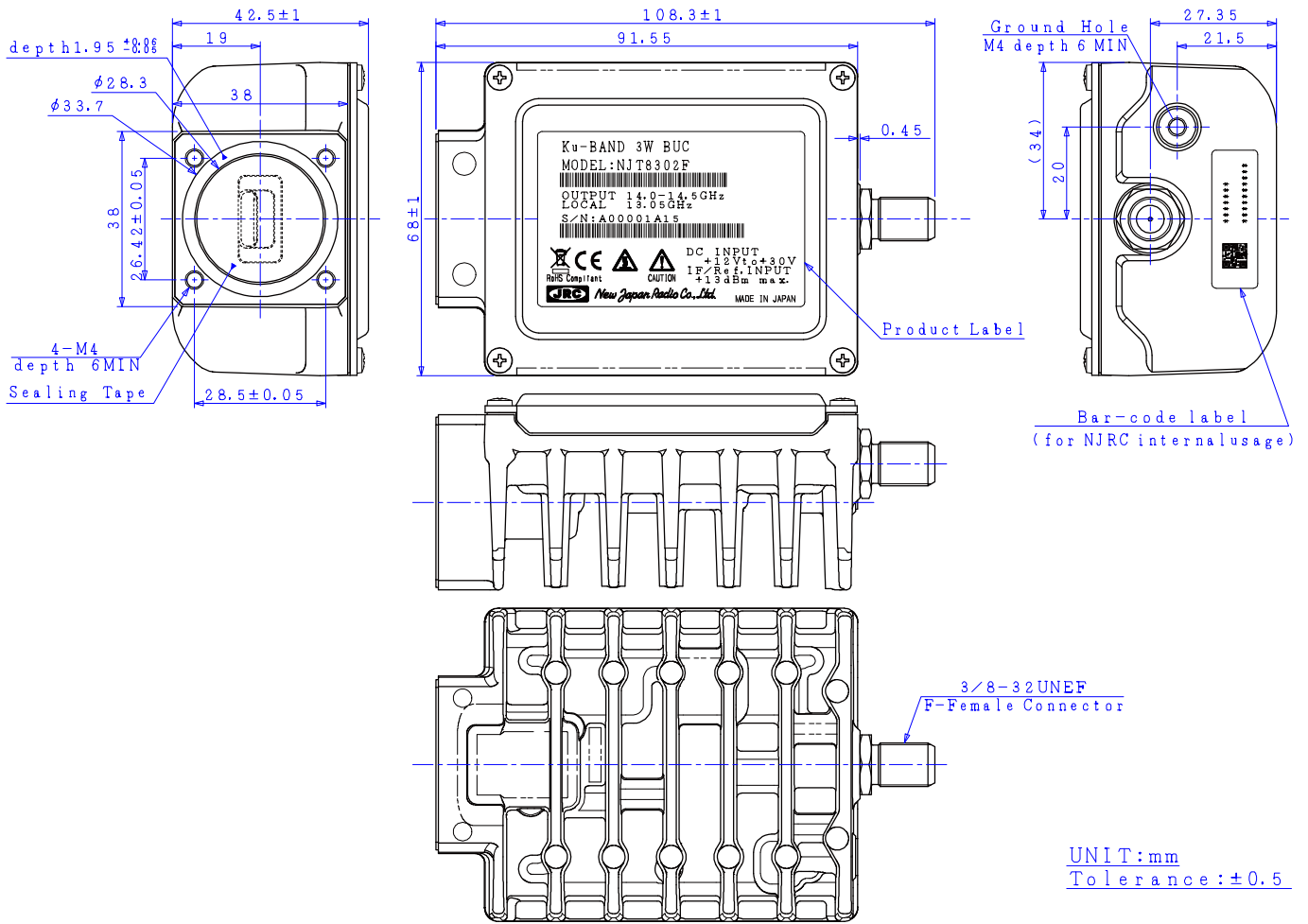

Caution: *DO NOT* remove the sealing tape on the waveguide. If the sealing tape is removed, it may lose the performance of waterproof.

* Above Specifications are subject to change without notice.

5. Label

Product Label

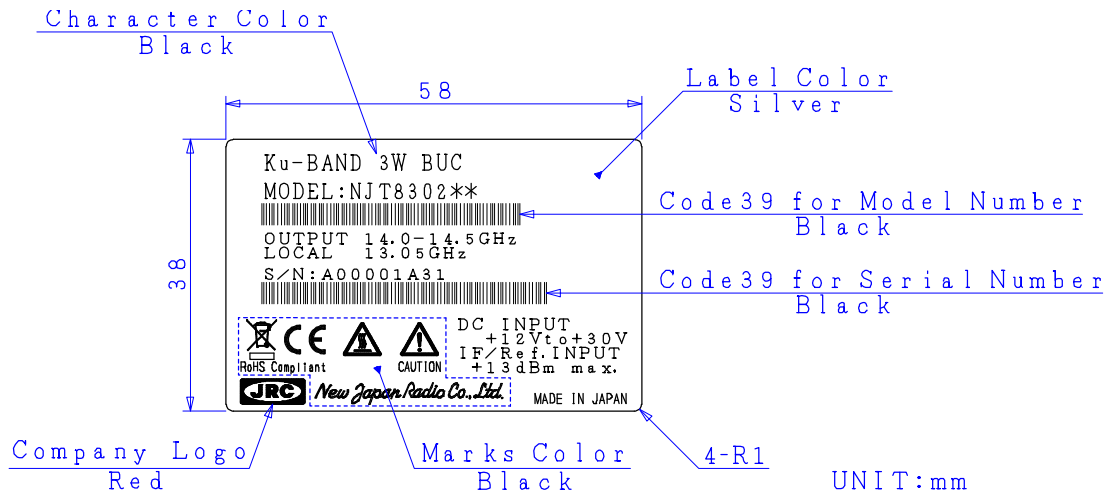

Definition of Serial Number

Serial Number (OSSSSRYM) - ALPHANUMERIC (9 characters)

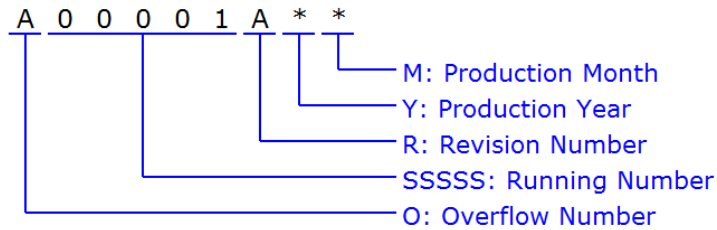

O: Overflow Number - ALPHABET (1 character)

"A" to "Z", e.g.: A99999 ⇒ B00001

SSSSS: Running Number - NUMBER (5 digits)

"00001" to "99999"

R: Revision Number - ALPHABET (1 character)

"A" to "Z"

Y: Production Year - NUMBER (1 digit)

Calendar Number, e.g.: 2009:9, 2010:0, 2011:1, 2012:2 ...

M: Production Month - ALPHANUMERIC (1character)

"1" to "9", "X" as October, "Y" as November, "Z" as December

* Above Specifications are subject to change without notice.

6. Package

Individual Package

Accessories

- O-ring
- Cross Recessed Head Screws
M4×10 4 pieces(SUS, SW and W) for Waveguide Flange Holes
M4×6 1 piece(SUS, SW and W) for Ground Hole

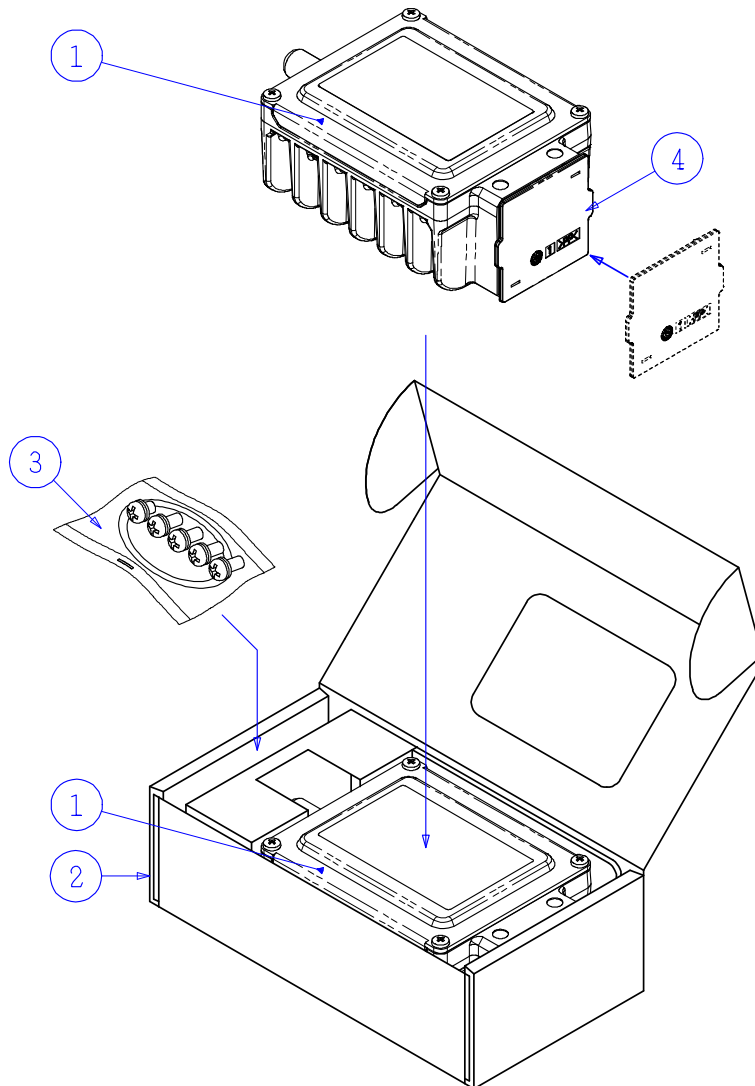
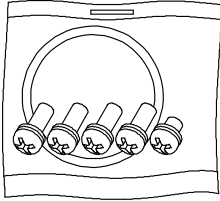

- ①: BUC
- ②: Single Wall Corrugated Fiberboard
- ③: Accessories
- ④: Polypropylene Flange Cover

UNIT:mm

* Above Specifications are subject to change without notice.