



STA3318 Series, StellarMini™ 180 W, Ku-Band, Antenna Mount TWTA (Optional Lineariser)

The STA3318 range of Ku-Band TWT amplifiers from SpacePath Communications provide over 150W of output power in a compact, lightweight, rugged, weatherproof, antenna mount enclosure. The advanced packaging and cooling techniques enable the unit to operate in extreme environmental conditions from direct rain to direct sunlight. The amplifiers can be deployed globally, are easy to integrate, user-friendly, and incorporate a comprehensive remote control facility as standard via an RS422/485 serial bus with Ethernet options.

The HPA incorporates a high efficiency dual collector TWT powered by a state-of-the-art power supply that further advances the company's reputation for robust, reliable product. In addition the circulator, receive band filter and harmonic filter are included as standard, eliminating the need for additional external components. With the internal Lineariser fitted, it offers twice the useable output power.

The STA3318 is available with a wide range of options and accessories, backed by round-the-clock, worldwide technical support.

OPTIONS

- Gain control
- L-band block upconverter
- Break-out link for upconverter
- Internal Lineariser

FEATURES

- Lightweight and compact
- High operating temperature
- Circulator, receive band filter and harmonic filter included as standard
- Weatherproof antenna mount construction allows exposed mounting

- Redundant control – contains control and drive circuits for 1:1 redundancy
- Stand-alone setting – automatically sequences to transmit mode
- Wide range of accessories including: controllers, waveguide networks, cable assemblies, ducting adaptor and cowl
- Round-the-clock hotline support
- RoHS compliant
- CE compliant

BLOCK DIAGRAM

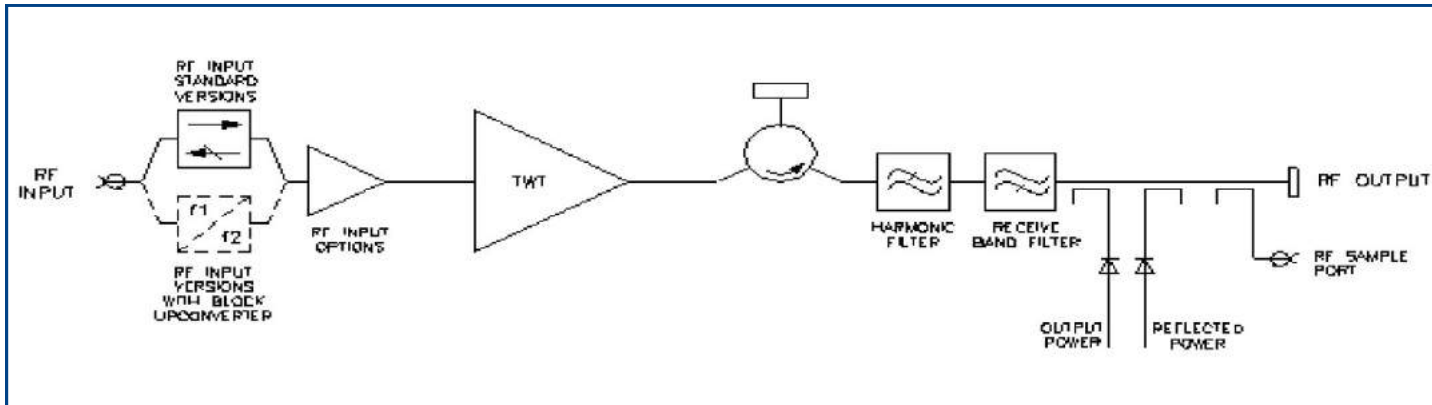

PERFORMANCE (Without Upconverter)

Frequency range:	
Standard - KU1	13.75 to 14.5
extended - KU2	12.75 to 14.5
extended - KU3	13.75 to 14.8
Output power:	
TWT output flange	175
HPA rated output	150
Gain:	
at rated power (A, D option)	61
SSG P _{1dB} -10dB (A, D option)	66
Attenuation range (D option).....	25
Gain variation:	
over any 80 MHz band	1.0
slope.....	0.1 dB/MHz max
Gain stability 24hrs (constant drive, temperature and load).....	0.5
Gain stability over full operating temperature..	2.0
Intermodulation (two equal carriers) with total output =	
(Standard Mini) P _{rated} -4 dB:	-18
(With Lineariser) P _{rated} -4 dB:	-28
performance with harmonic output	-60
AM to PM conversion at P _{med} -6 dB 2.5°/dB	
Noise power:	
transmit band.....	-70 dBW/4 kHz max
receive band:	
10.95- 12.75 GHz-standard	-150 dBW/4 kHz max
Residual AM:	
< 10 kHz.....	-50
10 kHz < f < 500 kHz	-20(1.5+log f)
>500 kHz.....	-85
Group delay:	
linear	0.01
parabolic	0.005
ripple.....	1.0
Phase noise:	
continuous.....	10 dB lower than IESS phase noise profile
AC fundamental	-50
sum of all spurs.....	-47
Input VSWR (operating).....	1.3:1
Output VSWR (non-operating)	1.3:1
Load VSWR, no damage.....	2.0:1

ELECTRICAL

Prime power	single phase, line-neutral or line-line
Voltage	99 to 265 V
Frequency	47 to 63 Hz
Power requirement	850 VA max
Power factor	0.95 min

MECHANICAL

Weight.....	9.0 kg (19.8 lb) typ
GHz Dimensions	see outline
GHz Cooling.....	integral forced-air
GHz	

CONNECTORS

W min	RF input.....	N-type female
W min	RF output	PBR120 with 6-32 UNC 2B threaded holes
	RF sample port.....	N-type female
dB min	Prime power.....	Amphenol T3110-000
dB min	Control interface.....	62GB-12E-18-32-PN
dB min		

Note: Mating connectors for the mains supply and control interface are supplied.

ENVIRONMENTAL

The amplifier complies with EU Directive 2002/95/EC, the RoHS Directive, restricting the use of hazardous substances in electronic equipment.

The amplifier falls within the scope of EU Directive 2002/96/EC, the WEEE Directive, governing disposal at end of life. Users should contact SpacePath Communications or their distributors for disposal information.

Operating temperature	-40 to +55 °C
Derating	2 °C/300 m above sea level (3.6 °F/1000 ft)
Solar gain	1120 W/m ²
Storage temperature	40 to +85 °C
Relative humidity (condensing)	100 %
Altitude:	
operating	4.5 km (15,000 ft) max
non-operating	12 km (40,000 ft) max
Vibration/shock	BS EN 60721-3-2 Level 2M3

For operation outside these parameters, refer to SpacePath Communications for guidance.

CONTROLS

Type	Function
REMOTE CONTROL	Off Standby Transmit RF inhibit
REMOTE STATUS/MONITOR	High Power Alarm Set Low Power Alarm Set Auto Redundancy Control RF Switch Control Gain Control (when fitted)
INTERFACES	Off Warm-up Standby Transmit Fault Summary Reflected Power External interlock TWT too hot Mean Helix Current Peak Helix Current High Power Alarm Low Power Alarm
Other Features	Output Power Monitor Reflected Power Monitor Helix Current Monitor Helix Voltage Collector Voltages Heater Voltage Heater Current Elapsed Hours
	RS-422/485, Optional Ethernet Dry Relay Contact
	Auxiliary Output Voltage Redundant system & waveguide switch drive 'Stand Alone' setting for automatic power up

***Note:** User Interface provides: Transmit On/Off control, Status Outputs, Summary and Redundancy Fault Outputs.

OPTIONS

Extensive options are offered with the STA3318 and include: integral pre-amplifiers, gain control and block upconverters. The options are defined by adding to the base number as shown below:

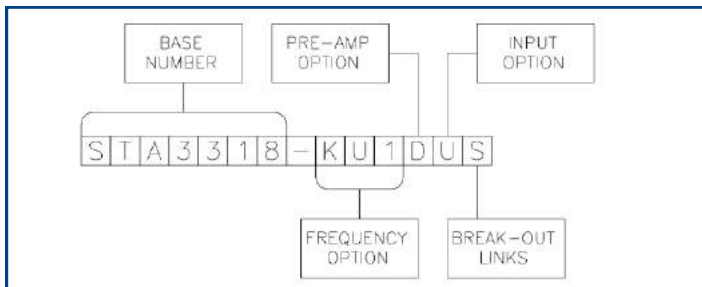

(Consult SpacePath Communications for availability of options).

Frequency Options

The STA3318 is offered in a number of frequency bands:

KU1 - 13.75 – 14.50 GHz

KU2 - 12.75 – 14.50 GHz

KU2 - 13.75 – 14.80 GHz

Pre-Amp Option

The pre-amp option can be selected from any of the following:

A - Integral solid-state amplifier (typical SSG 78 dB).

D - As option 'A' but includes an attenuator to provide 25 dB (min.) of gain control.

Input Option

The STA3318 can be offered with an L-Band Block Upconverter. Specify:

N - Standard RF

U - L – Ku Band Upconverter (see page 4)

Note: the upconverter requires the inclusion of either the 'D' or 'Z' options. (Consult SpacePath Communications for availability).

Break-Out Links

Available only with the upconverter option, this enables bypassing of the upconverter and can be used for monitoring, set-up, redundant switching etc. Specify 'S' for Break-Out Links (leave blank if not required).

ACCESSORIES

The STA3318 is supplied with an operation manual, prime power connector mating part, interface connector mating part. Additional accessories include:

- **N6081x-01 Series Control Unit***

Provides basic control of single HPA.

- **SPC1U01 1:1 Control Unit**

Provides control of 2 HPAs in 1:1 switch configuration. (The waveguide switch network can also be supplied).

- **Cable Assemblies**

For connecting STA3318 to controllers and waveguide switches.

- **DPP710351BA Transition**

Provides an interface for ducting and cowl fitment.

- **DPP710353BA Cowl**

For more information on accessories, contact SpacePath Communications.

***Note:** Existing controllers may require software upgrade.

PERFORMANCE WITH INTEGRAL BLOCK UPCONVERTER

Output frequency range:

option KU1 13.75 to 14.5
 option KU2 12.75 to 14.5

L-band input:

frequency range option KU1 950 to 1700
 frequency range option KU3 950 to 1450
 level 10

LO frequency:

option KU1 12.8
 option KU3 13.05

External reference:

frequency 10
 level -3 to +7
 impedance 50

Output power:

TWT output flange 175
 HPA rated output 150

Gain:

at rated power (D option) 61*
 SSG Prated -10 dB (D option) 66*
 Attenuation range (D option) 25

Gain variation:

full band 4.0
 over any 40 MHz band 1.5
 slope 0.08

Gain stability 24hrs (constant drive, temperature and load) 0.5

Gain stability over full operating temperature 2.0

Intermodulation (two equal carriers) with total output = Prated -4 dB:

options A, D -23
 Harmonic output -60

AM to PM conversion at Prated -6 dB 2.5

Noise power:

transmit band -70
 receive band (10.95 - 12.75 GHz) -150

Residual AM >100 kHz from carrier -60

Group delay:

linear 0.01
 parabolic 0.005
 ripple 0.5

Phase noise:
 continuous meets IESS phase noise profile
 AC fundamental -50 dBc
 sum of all spurs -47 dBc
 Input VSWR (non-operating) 1.6:1 max
 Output VSWR (non-operating) 1.3:1 max
 Load VSWR, no damage 2.0:1 max
 *Note: For S-Link version, gain is decreased by 4 dB.

CE CERTIFIED

EMC Directive 2004/108/EC, Low Voltage Directive 2006/95/EC
 EMC: Emissions EN61000-6-3:2001
 CFR45 Part 15B
 AUS/NZ 4251.1
 Immunity EN61000-6-2:2001

SAFETY

EN60950-1
 NRTL Listed to ANSI/UL 60950-1-2007 and
 CAN/CAS-C22.2 No 60950-1-07
 IECCB Certified to IEC 60950-1Ed2-2005

HEALTH AND SAFETY HAZARDS

Stellar satellite amplifiers are safe to handle and operate provided that the relevant precautions are observed. SpacePath Communications does not accept responsibility for damage or injury resulting from the use of electronic devices it produces.

High Voltage

Dangerous voltages are present within the TWT amplifier when operating normally. However, the equipment is designed so that personnel cannot come into contact with high voltage circuits unless covers are removed.

RF Radiation

All RF connectors must be correctly fitted before operation.

Beryllia

The TWT in the amplifier contains Beryllium Oxide ceramic parts. These are not accessible unless the TWT casing is damaged. Consult SpacePath Communications regarding the disposal of damaged or life expired tubes.

OUTLINE

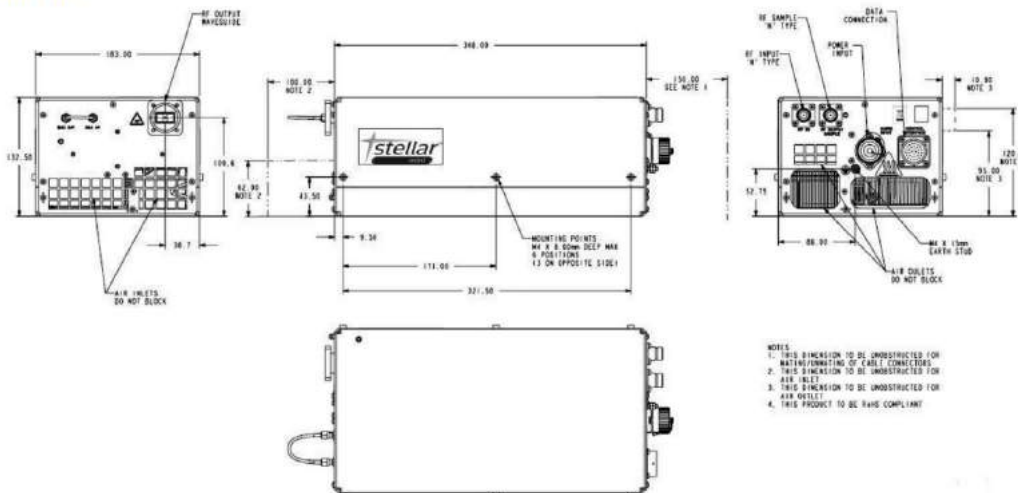

Packed Gross Weight
 & Dimension
 9.80kg 57x33x29cm

Whilst SpacePath Communications has taken care to ensure the accuracy of the information contained herein it accepts no responsibility for the consequences of any use thereof and also reserves the right to change the specification of goods without notice. SpacePath Communications accepts no liability beyond the set out in its standard conditions of sale in respect of infringement of third party patents arising from the use of tubes or other devices in accordance with information contained herein.