



STR1140 Series, 400W, C-Band, Rack Mount TWTA

The new generation of STR Series rack mount TWTA's provide an easy to operate, colour touch screen interface with a multi-functional selector wheel. The colour touch screen display provides clear, easy to read status of the amplifier's operation, including: RF output power monitoring, heater, helix monitoring, & TWT temperature. Set up screens are intuitive and simple to manage and the touch panel allows full local control and monitoring of all amplifier parameters, including automatic level control, system event logging and graphical trend analysis. Remote control operation can be made via RS485 or through an Ethernet interface, and a web page interface is also available. If a redundancy system is required, this can be set up and controlled via the touch screen. Changes to operating parameters can be locked and password protected if required.

The HPA incorporates a high efficiency multi-collector TWT powered by an advanced power supply built on over 30 years of experience in the design and manufacture of satellite amplifiers. The company's products have an enviable reputation for performance, robust quality and reliable service.

The STR1140 is available with a wide range of options and accessories, backed by round-the-clock,

Options

- Integral solid-state amplifier (SSA)
- L-Band Block upconverter
- 10MHz reference
- Lineariser
- Redundant system control
- Quick connect waveguide options

Features

- Compact 4RU enclosure
- Touch screen control
- Ethernet interface
- Remote diagnostics
- Forward and reverse power monitoring
- TWTA performance Data and Event logging

BLOCK DIAGRAM

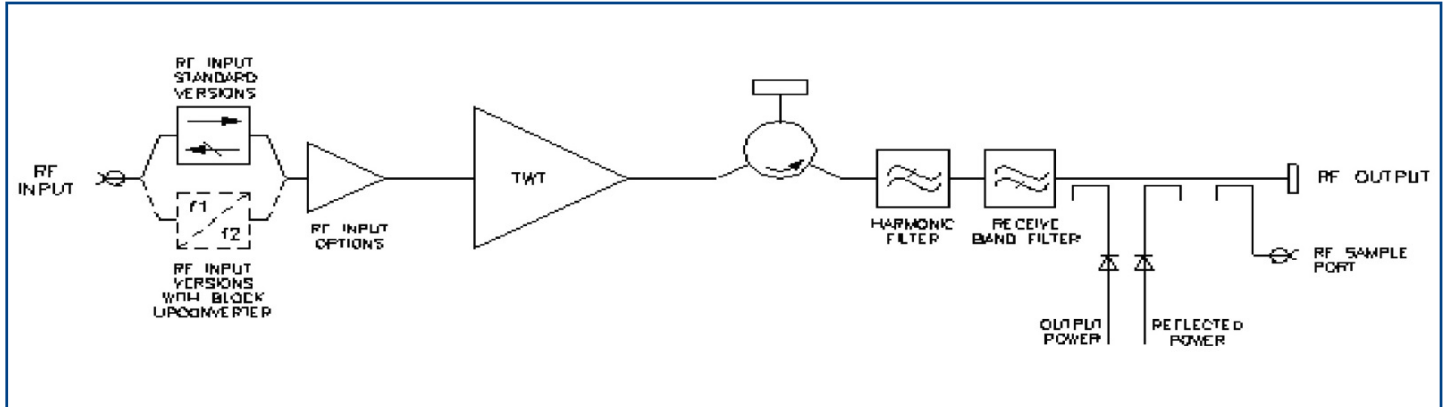

PERFORMANCE (Without Upconverter)

Frequency range:		
Standard - CC1.....	5.85 to 6.425	GHz
Other frequency ranges available - see page 3)		
Output Power:		
TWT output flange.....	400	W min
HPA rated output	350	W min
Gain:		
At rated power (A,D, Z option)	70	dB min
SSG $P_{rated} - 10dB$ (A,D,Z option)	75	dB min
Attenuation range (D,Z option)	25	dB min
Gain Variation:		
Over any 575 MHz band	2.5	dB max
Over any 80 MHz band	1.0	dB max
Slope.....	0.08	dB/MHz max
Gain stability 24hrs (constant drive, temperature and load)	0.5	dB max
Gain stability over full operating temperature	2.0	dB max
Intermodulation (two equal carriers) with total output = $P_{rated} - 4dB$:		
Options A, D	-18	dBc max
Performance with linearised option, Z.....	-26	dBc max
Harmonic output	-60	dBc max
AM to PM conversion at $P_{rated} - 6dB$	2.5	°/dB
Noise Power:		
Transmit band	-70 dBW/4 kHz max	
Receive band (3.2-4.2 GHz)	-150 dBW/4 kHz max	
Residual AM:		
<10kHz.....	-50	dBc max
10kHz < f < 500kHz	-20 (1.5+ log f)	dBc max
>500kHz	-85	dBc max
Group delay:		
Linear.....	0.01	ns/MHz
Parabolic.....	0.005	ns/MHz ²
Ripple.....	0.5	ns p-p
Phase Noise:		
Continuous	10dB lower than IESS phase noise profile	
AC fundamental.....	-50	dBc max
Sum of all spurs	-47	dBc max
Input VSWR (operating)	1.3:1	max
Output VSWR (non-operating)	1.3:1	max
Load VSWR, no damage.....	2.0:1	max

ELECTRICAL

Prime power.....	single phase
Voltage	99 to 265 V
Frequency	47 to 63 Hz
Power requirement.....	1500 VA max
Power factor	0.95 min

MECHANICAL

Weight.....	25Kg (75lb) typ
Dimensions.....	see outline
Cooling	integral forced-air

CONNECTORS

RF input.....	N-type female
RF output	PBR120 with 6-32 UNC 2B threaded holes
RF Sample port.....	N-type female
Prime Power.....	C20 Male IEC
RS232	D-Sub 9P
RS485 (4-Wire)	D-Sub 9S
Ethernet	RJ45
Auxiliary Interface.....	D-Sub 25P
WG Switch.....	D-Sub 15S
USB Port.....	USB A

Note: Mating connectors for the mains supply, RS232, RS485, Aux Int and WG Switch are included.

ENVIRONMENTAL

For operation outside these parameters, refer to SpacePath Communications for guidance.	
Operating temperature (see note 1).....	-10 to +50 °C
Derating	2 °C/300 m above sea level (3.6 °F/1000ft)
Storage temperature	-50 to +80 °C
Relative humidity (non-condensing)	95 %
Altitude:	
Operating.....	4.5 Km (15,000 ft)max
Non-operating	12 Km (40,000 ft)max
Vibration	BS EN 600668-2-64 test Fh, transportation
Shock.....	IEC Publication 68-2-27 Part 2 test Ea, 25g
EMC:	
EN61000-6-4:2001 (Emissions)	
EN61000-6-2:2001 (Immunity)	
FCC CFR47 Part 15	
Acoustic Noise.....	68 dBa typ
Heat Dissipation	1500W to duct 350W to room

INTERFACE

Type	Function	
CONTROLS	LOCAL	AC Power On/Off
	FRONT PANEL TOUCH SCREEN (Front panel touch screen controls include but are not limited to the functions opposite)	HPA State (Standby, Transmit etc) Gain Automatic Level Control and Go To Power Configuration, single HPA, 1:1 Redundant High/Low power Alarms System Set Up
STATUS	FRONT PANEL TOUCH SCREEN (Front panel touch screen status include but are not limited to the parameters opposite)	HPA State Forward and Reverse Power TWT Parameters (Temperature, Voltages) Logs and Trend Analysis Fault Conditions Elapsed Hours
	DRY-FORM- C RELAY CONTACTS	Summary Fault
M&C	SERIAL ETHERNET	RS232 and RS485 (4-wire) Webpage, TVN, TCP, SNMP
	AUXILIARY INTERFACE	Summary Fault RF Inhibit +24V, +15V Supply
	WG SWITCH	WG Switch drives for 1:1 Redundant System
	USB Port	Log and Trend Analysis download

OPTIONS

Extensive options are offered with the STR1140 and include; integral pre-amplifiers, gain control, linearisers and block upconverters. The options are defined by adding to the base number as shown

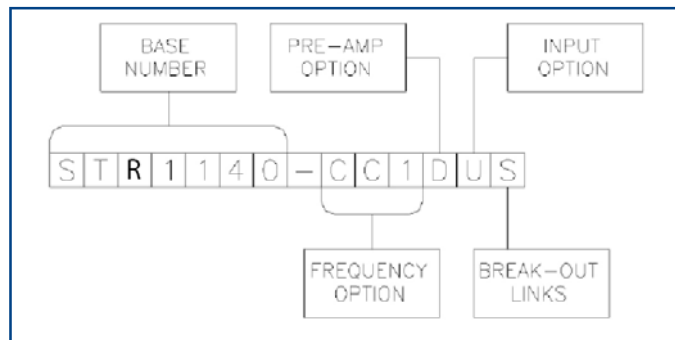

(Consult SpacePath Communications for availability of options)

Frequency Options

The following frequency options are available

Ref	Frequency Range (GHz)	BUC Option
CC1	5.85—6.425	Yes
CC2	5.85—6.65	Yes
CC3	5.85—6.75	Yes
CC4	5.85—7.025	Yes

Pre-Amp Option

The pre-amp option can be selected from any of the following:

- A - Integral solid-state amplifier (typical SSG 78 dB)
- D - As option 'A' but includes an attenuator to provide 25 dB (min) of gain control
- Z - Integral lineariser that improves the linearity of the HPA, providing a C/I of typically -26 dBc at 4dB OPBO. The lineariser also incorporates the pre-amp and gain control options.
(Consult SpacePath Communications for availability)

Input Option

The STR1140 can be offered with an L-Band Block Upconverter. Specify:

- N - Standard RF
- U - L to C-Band Block Upconverter (see page 4)

Note:

The upconverter requires the inclusion of the 'D' and 'Z' option. (Consult Spacepath Communications for availability)

For more information contact SpacePath Communications.

PERFORMANCE WITH INTEGRAL BLOCK UPCONVERTER

Output frequency range - see Frequency Options

L-Band input:

Frequency range option CC1.....	950 to 1525	MHz
Frequency range option CC2.....	950 to 1750	MHz
Frequency range option CC3.....	950 to 1850	MHz
Frequency range option CC4.....	950 to 2125	MHz
Level	10	dBm max

LO frequency

All options	4.9	GHz
-------------------	-----	-----

External reference (see note):

Frequency	10	MHz
Level	-3 to +7	dBm
Impedance	50	Ω

Gain Variation:

Over Any 575 MHz band	4.0	dB max
Over any 40 MHz band.....	1.5	dB max

Phase Noise Continuous..... meets IESS phase noise profile

Input VSWR (non-operating)..... 1.6:1 max

Note: The BUC can be operated without the external reference, typical frequency stability ± 0.25 ppm.

HEALTH AND SAFETY HAZARDS

Stellar satellite amplifiers are safe to handle and operate provided that the relevant precautions are observed. Spacepath Communications does not accept responsibility for damage or injury resulting from the use of electronic devices it produces.

High Voltage

Dangerous voltages are present within the TWT amplifier when operating normally. However, the equipment is designed so that personnel cannot come into contact with high voltage circuits unless covers are removed.

RF Radiation

All RF connectors must be correctly fitted before operation.

Beryllia

The TWT in the amplifier contains Beryllium Oxide ceramic parts. These are not accessible unless the TWT casing is damaged. Consult Spacepath Communications regarding the disposal of damaged or life expired tubes.

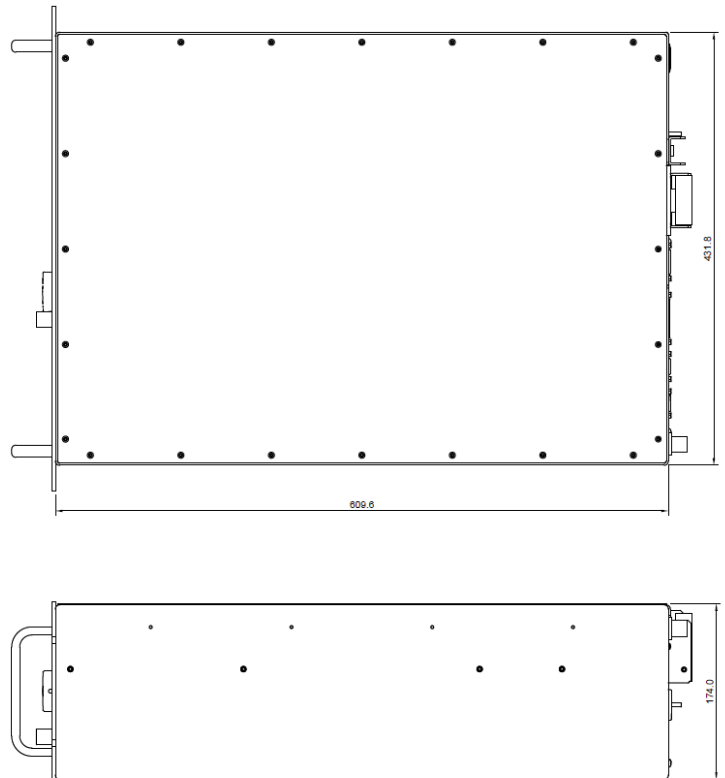
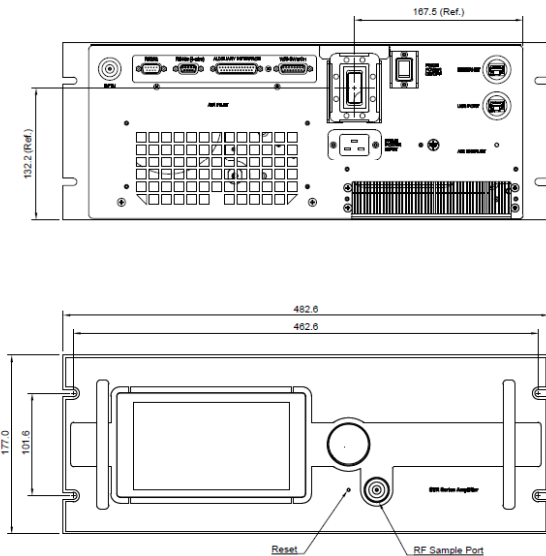

Whilst SpacePath Communications has taken care to ensure the accuracy of the information contained herein it accepts no responsibility for the consequences of any use thereof and also reserves the right to change the specification of goods without notice. SpacePath Communications accepts no liability beyond the set out in its standard conditions of sale in respect of infringement of third party patents arising from the use of tubes or other devices in accordance with information contained herein.