



BDC KU-BAND EXT REF 1000X SERIES



SPECIFICATIONS

Noise Figure	15 dB max. at room temp.
L.O. Stability	Phase Locked to External Reference
Phase Noise (SSB) max.	Depends on External Reference
Input VSWR	1.8 : 1 max.
Output VSWR	2.0 : 1 max.
Gain	20 dB typ., 18 dB min., 22 dB max.
Gain Flatness (over full band)	≤ 4 dB p-p
Output P1dB	+ 5 dBm min.

DC Power	+ 15V to + 24V DC
Via	Feed-Through and Output Connector Output Connector Feed-Through
Current	300 mA max.
Input (waterproof)	SMA-Connector (50 Ohm)
Output (waterproof)	F-Connector (75 Ohm) N-Connector (50 Ohm) SMA-Connector (50 Ohm)
Dimensions (L x W x H)	107 mm x 78 mm x 44 mm (4.21 in x 3.07 in x 1.73 in)
Weight	300 g (10.60 oz)
Operating Temperature	- 40 to + 60°C
Storage Temperature	- 40 to + 80°C
External Ref Freq	10 MHz (sine-wave), -10 to 0 dBm

FREQUENCY BANDS

	1000XA	1000XB	1000XC	1000XAE	1000XGE
Frequency Band (GHz)	11.70 - 12.20	12.25 - 12.75	10.95 - 11.70	11.70 - 12.75	10.70 - 11.70
L.O. Frequency (GHz)	10.75	11.30	10.00	10.75	9.75
IF Frequency (MHz)	950 - 1450	950 - 1450	950 - 1700	950 - 2000	950 - 1950

HOW TO ORDER

BDC-1000XAND-10S

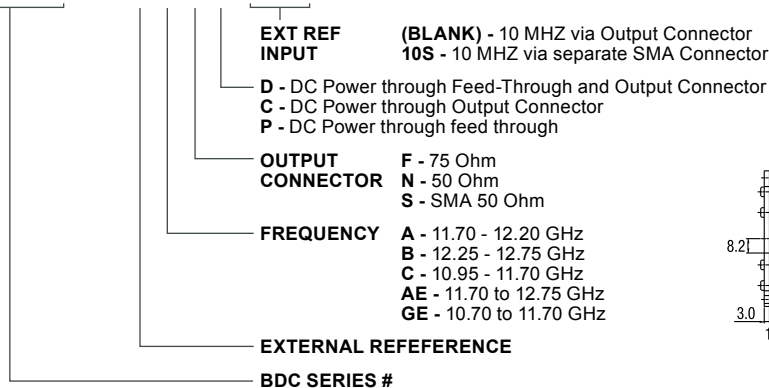

MECHANICAL DIAGRAM

