



LNB

KA-BAND AUTO-REF

9000HX-O3B



SPECIFICATIONS

Noise Figure	1.6 dB max. at room temp. @ CF
L.O. Stability	± 25 KHz in PLL mode
Phase Noise (SSB) max.	-70dBc @ 1KHz -80dBc @ 10KHz
Input VSWR	2.0 : 1 max.
Output VSWR	2.0 : 1 max.
Gain	58 dB typ., 55 dB min., 65 dB max.
Gain Flatness (over full band)	≤ 3 dB p-p
Output P1dB	+ 5 dBm min.

DC Power	+ 11V to + 26V DC (See below for Band Select)
Current	300 mA max.
Input (waterproof)	WR-42 waveguide grooved
Output (waterproof)	F-Connector (75 Ohm) N-Connector (50 Ohm)
Dimensions (L x W x H)	140 mm x 66 mm x 39 mm (5.5 in x 2.6 in x 1.53 in)
Weight	500 g (17.6 oz)
Operating Temperature	- 40 to + 60°C
Storage Temperature	- 40 to + 80°C
External Ref Freq	10 MHz (sine-wave), -10 to 0 dBm

FREQUENCY BANDS

	O3B-A	O3B-B
Frequency Band (GHz)	17.852 - 18.588	18.372 - 19.271
L.O. Frequency (GHz)	16.8	17.4
IF Frequency (MHz)	1052 - 1788	972 - 1871

HOW TO ORDER

9000HX-O3B-AN

CONNECTOR	F - 75 Ohm N - 50 Ohm
FREQUENCY	A: 17.852 – 18.588 GHz B: 18.372-19.271 GHz
LNB SERIES #	

MECHANICAL DIAGRAM

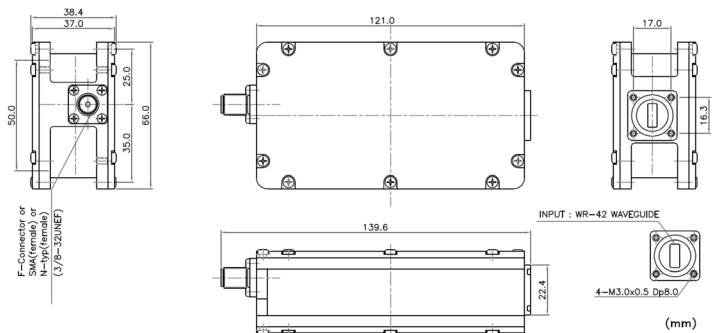

Esatcom Inc
Norsat authorized distributor

Tel
718.276.0800

Email
sales@esatcom.com

