

Dual System

Key features

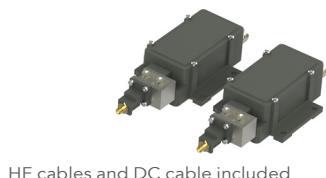

- Auto LO ref Ext. 10 MHz / Internal ± 2.5 ppm
- High P1dB and IP3
- Excellent Phase noise meets all profiles of DVB-S2X.
- Customized LO as option
- Alarm and Monitoring & Control as option



Description

The Ka-Band Dual Systems provides coverage of the Ka receive band. The system consists of Ka LNA Wideband with waveguide isolator, Ka BDC's with waveguide isolators and matched HF cables. Excellent Phase Noise to support all profiles of DVB-S2X services.

Options include customized LO, customized frequency ranges, customized gain, separate DC power input and separate input for the external 10 MHz reference. As an option the SMW M&C interface provides possibility to daisychain several units in one Modbus RTU RS485 network for the optional Alarm and Monitoring & Control functionality.

BDC connector (standard)

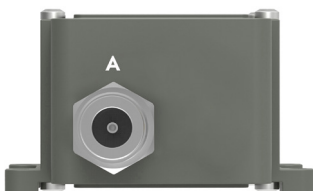

Connector A (standard)
 Type: N-f, (option F-f or SMA-f)
 Functions: L-Band out, DC in, External 10 MHz in

BDC connectors (optional)

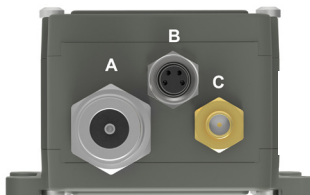

Connector B (optional)
 Type: M8 female, 4 pin, A-coded
 Functions: Alarm and M&C

Connector B (optional)



1 = Alarm open collector (max. 200 mA) or optionally DC input.
 2 = A pos- RS485
 3 = B neg- RS485
 4 = Common (GND)
 5 = Shield

Connector C (optional)
 Type: SMA-f only
 Functions: Ext. 10 MHz in and/or DC input

Dual System

Technical specifications

MODEL		18.20 - 20.20 GHz
INPUT	Input frequency	BDC 1: 18.20-19.20 GHz BDC 2: 19.20-20.20 GHz
	LO frequency	BDC 1: 17.25 GHz BDC 2: 18.25 GHz
	Input LNA	Waveguide WR 42 / R 220. Flange PBR 220.
	Input BDC	SMA female 50Ω
	DC Input BDC	+12 to +24 V through output connector or separate SMA connector (optional), power consumption 5W typ.
	DC input LNA	+12 to +24 V / 110 mA typ. Supplied through separate SMA connector via included DC cable, mated from BDC # 1
	Input VSWR LNA	1.35:1 max. with Isolator (included)
INTERNAL	LO ref.	Auto LO ref. External 10 MHz ref / Internal ±2.5 ppm -40 to +80°C
	External LO ref.	Sine wave, Level -10 to +10 dBm. Supplied through output connector.
	LO Leakage	-60 dBm max. @ RF input
	Gain	60 dB typ. (55dB min.)
	Flatness	±0.4 dB within 30 MHz, ±2 dB max. over each band
	Noise figure	1.8 dB / 149 K typ.
	Phase Noise	-35 dBc @ 10 Hz -65 dBc @ 100 Hz -80 dBc @ 1 kHz -85 dBc @ 10 kHz -95 dBc @ 100 kHz -112 dBc @ >1 MHz typ.
Image Rejection	30 dB min.	
OUTPUT	IF output	950-1950 MHz, (950-2250 MHz optional)
	Output P1dB	+ 15 dBm
	Output IP3	+ 25 dBm
	Output VSWR BDC	1.7:1 typ.
	Output connector LNA	SMA-type 50Ω
Output Connector BDC	N-type 50Ω , SMA-type 50Ω or F-type 75Ω	
GENERAL	Alarm (option)	Sum alarm, set via M&C to alarm in any combination of: LNA failure, Total current, LO lock (Ext/Int/n/a), signal power high/low, Supply voltage low. Open collector 3.3 to 28 V, max. 200 mA (pull-up 10 k Ohm at host side), pin 1 in M8 connector.
	M & C (option)	Via MODBUS RTU RS485 electrical interface, see document Monitoring and Control technical interface for details. NOTE! Mates with M8 male connector/Cable, use only shielded CAT 5 cables
	Dimensions LNA	103 x 63 x 34 mm, including isolator
	Dimensions BDC	178 x 80 x 46 mm (F- & SMA-connector) 184 x 80 x 46 mm (N-connector) (for drawing, see www.smw.se)
	Weight LNA	160 including isolator
Weight BDC	399 g (F- & SMA-connector) 418 g (N-connector)	
Temperature range	Storage and operating: -40 to +80°C, -40 to +176°F	
OPTIONS	Options	Separate SMA connector on BDC for DC input or Ext. 10 MHz reference Alarm and Monitoring & Control Customized gain Customized LO Extended IF

Dual System

Example and wiring diagram

Example Ka-Band Dual System configurations					
P/N (x = connector type F, N or SMA)	Frequency range (GHz)	BDC	LO	Ka-band (GHz)	L-band (MHz)
55720x-V02 Auto LO ref. Ext. 10 MHz/Int.±2.5 ppm	18.20 - 20.20	1	17.20	18.20-19.20	1000-2000
		2	18.20	19.20-20.20	1000-2000
55721x-V02 Auto LO ref. Ext. 10 MHz/Int.±2.5 ppm	18.20 - 20.20	1	17.25	18.20-19.20	950-1950
		2	18.25	19.20-20.20	950-1950

NOTE P/N: x = "0" for F connector, "5" for N connector and "8" for SMA connector

Ka Dual Band system

NOTE: Cable lengths are fixed due to best performance of this system. If other cable lengths are needed, please contact us first.

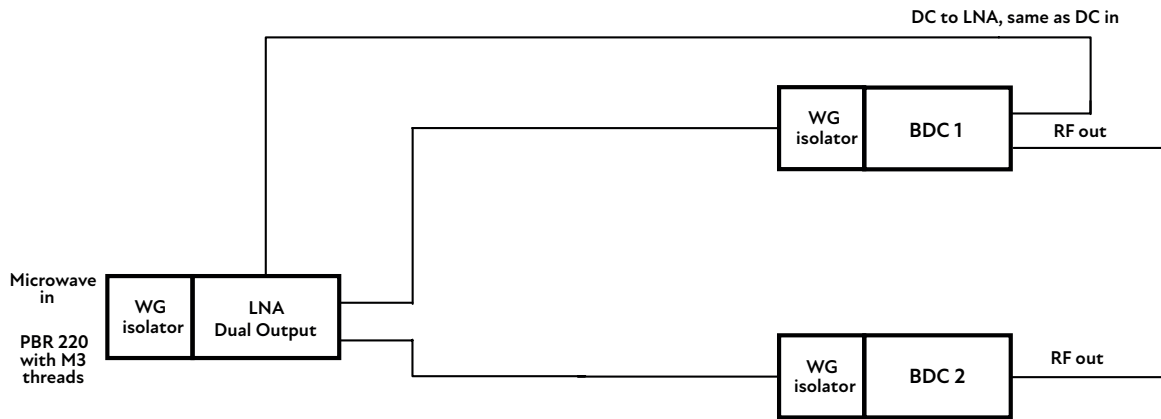

Dual System

Technical Drawing

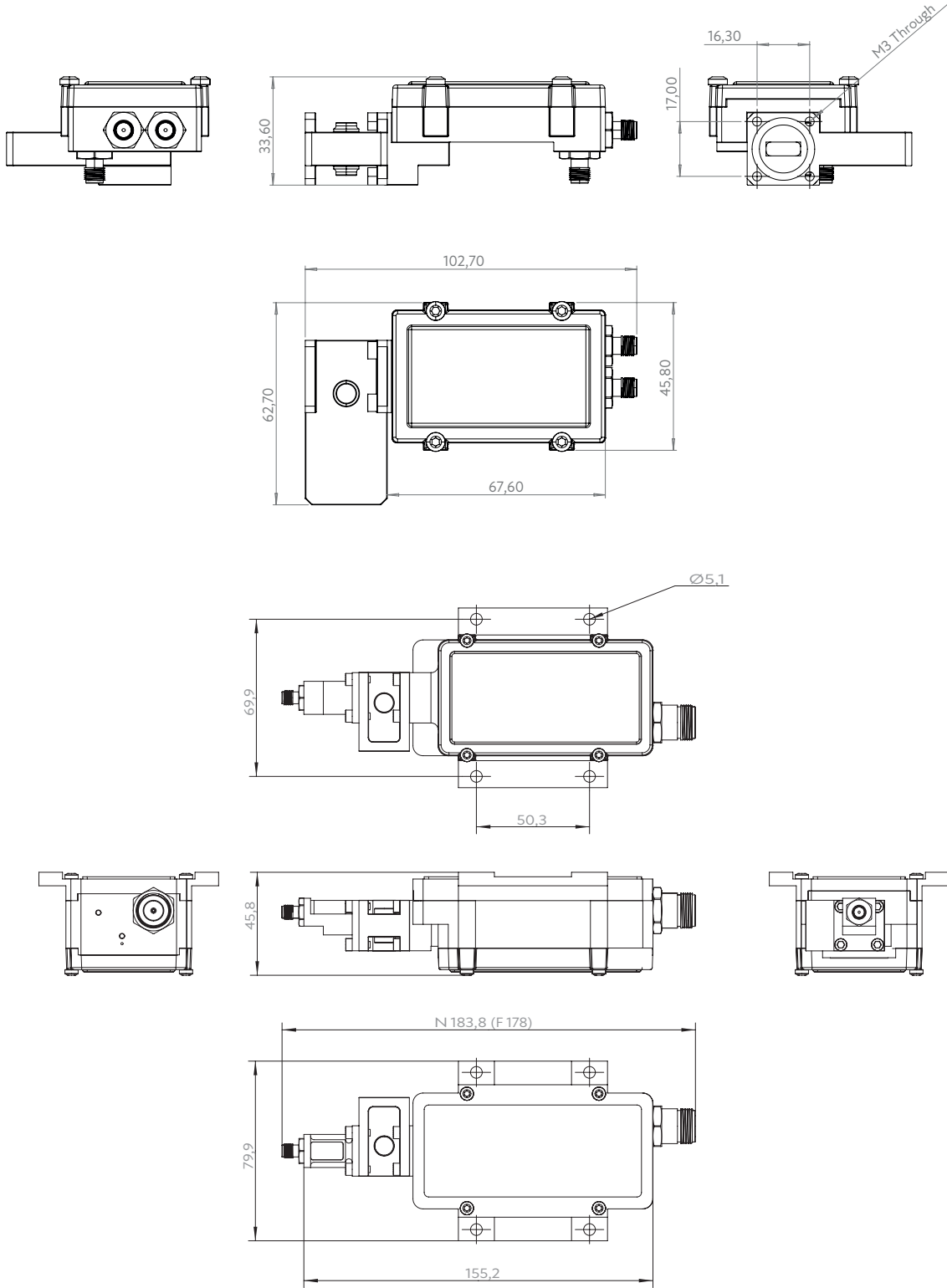

Professional Satcom Frequency Converters & Components. All products are fully CE and RoHS compliant and every unit includes full documentation of performance tests and quality control. Please contact sales@smw.se to configure or customize the unit to your needs. Visit smw.se or scan QR code to see our full product range and request a quote.

